



ST. CLAIR CATHOLIC
DISTRICT SCHOOL BOARD

Lighting the Way ~ Rejoicing in Our Journey

TENDER NUMBER: 642-CP1917

Playground Asphalt Replacement

Good Shepherd Catholic School

4 Edith Street, Thamesville, ON N0P 2K0

Submission Deadline and Location:

Thursday, June 13, 2019

2:00:00 PM Local Time

Reception Desk, Catholic Education Centre

420 Creek Street, Wallaceburg, ON N8A 4C4

1. INTRODUCTION

The St. Clair Catholic District School Board (hereafter referred to as the “SCCDSB” or the “Board”) invites interested parties to submit sealed submissions in response to this Request for Tender (“RFT”) document. The SCCDSB currently operates 26 elementary schools, 2 secondary schools, and an administrative office within the Municipality of Chatham-Kent and County of Lambton.

2. PURPOSE

The purpose of this bid document is to provide interested parties with sufficient information to enable them to prepare and submit bids for consideration by the SCCDSB, subject to the conditions herein.

3. DEFINITIONS

The following words are used throughout the bid document and proponents should note these conditions when completing their bid submission.

The word “MUST” shall mean proponents “must” include the required information in the bid submission. Failure to include the required information will deem the submission informal.

The word “SHOULD” shall mean proponents “should” include the required information in the bid submission.

The word “INFORMAL” shall mean bid submissions will be eliminated from further evaluation if the submission does not include the required information.

The word “CONTRACTOR” means an entity that submits a bid in response to this tender document, as the context may suggest, refers to a potential Contractor.

The word “SUBCONTRACTOR” means the subcontractor and/or business who contracts to provide some service or material necessary for the performance of another’s contract.

The word “QUALIFIED” shall mean a proponent who is compliant and has included the required information in their bid submission.

The word “INFORMAL” shall mean bid submissions will be eliminated from further evaluation if the submission does not include the required information.

“BID IRREGULARITY” means a deviation between the requirements (terms, conditions, specifications, special instructions) of a bid response for the purposes of this bid; bid irregularities are further classified as major irregularities or minor irregularities. The classification of what is a major irregularity or a minor irregularity shall be the sole discretion of the SCCDSB.

“BID SUBMISSION” means all of the documentation and information submitted by a Proponent in response to this request.

“APPLICABLE LAW” and “APPLICABLE LAWS” means any common law requirement and all applicable and enforceable statutes, regulations, directives, policies, administrative interpretations, orders, by laws, rules, guidelines, approvals and other legal requirements of any government and/or regulatory authority in effect from time to time.

The word “PROPONENT” means an entity that submits a bid in response to this tender document, as the context may suggest, refers to a potential Proponent.

4. RFT SCHEDULE

For the purposes of this RFT, the Board has established the following timing deadlines for the completion of the RFT process.

Event	Date & Time
Issue Date:	Friday May 24, 2019
Mandatory Site Visit:	Thursday, May 30, 2019 at 9:30 am. (Please refer to Section 25)
Last day to submit questions:	Wednesday, June 5, 2019 at 12:00 pm
Responses to Questions Received:	Friday, June 7, 2019
Closing Date and Time:	Thursday, June 13, 2019 at 2:00:00 pm

5. **RFT CONTACT**

Tony Prizio, Supervisor – Procurement
St. Clair Catholic District School Board
420 Creek Street, Wallaceburg, ON
P: (519) 627-6762 x10256
E: tony.prizio@st-clair.net

6. **ACCEPTANCE OF TERMS**

The submission of a bid by a Proponent represents that the Proponent has read and completely understands, and accepts all provisions contained within this RFT. Any bid that has alternative terms and conditions to those contained herewith may be considered a counteroffer to the Board’s request and may be rejected.

7. **SCOPE OF WORK**

The St. Clair Catholic District School Board (Board) is seeking a Contractor to provide all of the necessary materials, equipment and labour to complete playground asphalt replacement at Good Shepherd Catholic School, 4 Edith Street, Thamesville, ON.

8. **BID SUBMISSION**

Bids shall be submitted with the project clearly identified on the sealed envelope:

Bid Package #: 642-CP1917 – Playground Asphalt Replacement – Good Shepherd Catholic School

The sealed Bid Submission must be returned to:

Catholic Education Centre, 420 Creek St. Wallaceburg, ON N8A 4C4

Attention: Mr. Tony Prizio, Supervisor - Procurement

Bids MUST be received no later than the date and time specified in this tender document. Any bid submissions received after the deadline will be returned unopened to the bidder.

The Board will not take any responsibility for late submissions due to postal delay through Canada Post or other courier services.

Bids shall be filled out in ink or typed, signed in longhand by a duly authorized company official (having authority to bind) and sealed with a company corporate seal. One original of the fully completed Bid Form must be submitted. Failure to provide all of the requested information on the Bid Form may result in disqualification of the bid.

Bids by telephone, email, or fax will not be accepted.

After bid closing all submissions will be reviewed by the Board's evaluation team. Contractors submitting a bid are invited to stay for a public opening of Bids at 2:05 pm at the Catholic Education Centre.

Supplier's Bid Submission, all Bid Documents and CCDC 2-2008 Stipulated Price Contract will form the agreement.

9. CONTRACT PRICING

Proponents must complete the Bid Form provided with these bid documents. Prices must include all travel, reimbursements, delivery (FOB Destination).

10. QUESTIONS AND REQUESTS FOR CLARIFICATION

Proponents finding discrepancies, ambiguities or omissions in the RFT documents or having doubt as to the meaning or intent thereof, shall immediately notify the Procurement Department. The board is not responsible for any misunderstanding of the RFT on the part of a Proponent. Questions must be received by the date and time specified in the RFT Document. Verbal Answers will be only binding when confirmed by written addenda.

All questions to be addressed in writing to: Tony Prizio, Supervisor - Procurement
St. Clair Catholic District School Board
E-mail: tony.prizio@st-clair.net
CC: victoria.iaccino@st-clair.net

11. ADDENDA

Proponents may also, during the RFT Process, be advised by Addendum of any additions, deletions or alterations to RFT documents. All such Addenda shall become part of the RFT Documents.

If an addendum is issued, the document(s) will be made available to Proponents through the same platform that the original RFT documents were issued. Proponents are responsible for verifying before submitting its response that it has received all addenda that may have been issued.

12. WITHDRAWAL OF SUBMISSION

A Proponent may alter, amend, or withdraw a submitted proposal if such request is received in writing by the contact person for this RFT prior to the closing date and time specified in this document. The last submission shall supersede and invalidate all previous submission by that Proponent as it applies to this bid. Such requests received after the closing date and time will not be permitted.

13. BID ACCEPTANCE

It shall be understood by all proponents, that the RFT submission shall be valid and subject to acceptance by the Board, and that no adjustments shall be made to the proposal for a period of up to and including sixty (60) days from the RFT Closing Date.

The Board reserves the right to determine the successful proponent at its sole discretion. The lowest cost may not be accepted. The Board reserves the right to decline any or all submissions, in whole or in part, at any time prior to making an award.

The successful proponent shall be required to enter into a formal contract with the Board, which will include the terms and conditions of the RFT documents, the Proponent's bid, and all other applicable documents.

14. CANCELLATION

The Board may cancel this RFT at its discretion at any time prior to an award. The Board may do so without providing reasons and issue a new request for tender, request for qualifications, or do nothing.

15. CLARIFICATION

The Board reserves the right to seek clarification from any Proponents without being obligated to all Proponents if it finds certain aspects of a bid unclear.

16. BOARD'S RIGHT TO WAIVE MINOR IRREGULARITY

The Board reserves the right to accept or waive a minor irregularity, or where practical to do so the Board may as a condition of bid acceptance request a Proponent to correct a minor irregularity with no change in bid price. Items of non-compliance on any bid submissions which do not strictly comply with the provisions, procedures and requirements of this bid, or are incomplete, ambiguous, or which contain errors, alterations, misleading information, omissions, or irregularities of any kind, may be rejected and disqualified at the discretion of the Board. All proponents agree to provide all such additional information as, and when requested, at their own expense, provided no proponent in supplying any such information shall be allowed, in any way to change the pricing or other cost quotations originally given in its bid submission or in any way materially alter or add to the solution originally proposed.

17. ERRORS AND OMISSIONS

The Board will not be held liable part of the RFT. While the Board has used considerable effort to ensure an accurate representation in the RFT, the information contained in the RFT is supplied solely as a guideline for the Proponents. The information is not guaranteed or warranted to be accurate by the Board, nor is it necessarily comprehensive or exhaustive.

18. DOCUMENT AVAILABILITY

RFT documents are available on the Board's Website www.st-clair.net under Bid Opportunities or on Biddingo www.biddingo.com, along with Sarnia Construction Association, Windsor Construction Association, Lambton Area Builders Exchange and the London & District Construction Association.

The Board assumes no responsibility for the proponent's failure to examine all of the RFT Documents.

19. PROPONENT EXPENSES

Any and all costs and expenses incurred by Proponents in the development, preparation, submission or presentation of their bids, or otherwise related to its participation in this RFT process will be borne by the Proponents. The selection of any bid, or the rejection of any or all bids, or the termination/cancellation of

this RFT process, or initiation of a new RFT process shall not render the Board liable to pay or reimburse any such costs or damages incurred by any Proponent, or any partner or contractor of such Proponents.

20. VOLUNTARY ALTERNATE & SEPARATE PRICES

The bid amounts are to be based on the bid documents. Where there is any conflict within the bid documents, the bid amount shall include the higher cost alternative. Alternative proposals are encouraged and should be identified in the bid. Submit complete information including any impact on schedule to allow a full evaluation of the proposal including, as applicable, any particulars in which the alternate proposal is at variance with or unable to meet the specifications. Note also any impact on other trades if the alternative is accepted. Alternative proposals may be made without limitation, including for items specified as single sourced. A Substitution Request Form is included in Section 00 90 01 of these bid documents.

21. BID INELIGIBILITY

Bids that are unsigned, improperly signed or sealed, conditional, illegible, obscure, contain arithmetical errors, erasures, alterations, or irregularities of any kind may, at the discretion of the Owner, be declared informal.

Bids with Bid Forms and enclosures which are improperly prepared may, at the discretion of the Owner, be declared informal.

Bids that fail to include the required bonding, consent of surety may, at the discretion of the Owner, be declared informal.

Bids based on prices seeming to be so unbalanced as to adversely affect the interests of the Owner may, at the discretion of the Owner, be declared informal.

Bids based upon an unreasonable period of time for completion of the Work may, at the discretion of the Owner, be declared informal.

Bids that do not include Proof of Insurance may, at the discretion of the Owner, be declared informal.

22. AWARD

The Board has the right to reject any or all bids. The lowest Bid will not necessarily be accepted. The invitation to bid does not constitute an offer by the Contractor to enter into a contract. In the event of a tie, a coin flip conducted by the Supervisor – Procurement (or designate) with a minimum of one other Board staff will determine the successful proponent.

Acceptance of the Bid and/or award is subject to the approval of the St. Clair Catholic District School Board.

The SCCDSB reserves the right to withdraw the award of the contract to a successful bidder(s) within 30 days of the award if, in the opinion of the SCCDSB, the successful bidder(s) is unable or unwilling to enter into a form of contract satisfactory to the SCCDSB. The SCCDSB shall be entitled to do so without any liability being incurred by the SCCDSB to the bidder.

23. ENTITLEMENT TO A DEBRIEFING

In accordance with the Broader Public Sector Procurement Directive unsuccessful Bidders are entitled to a debriefing, during which they will be provided with feedback regarding their Tender. In order to be debriefed, unsuccessful Bidders must contact the Owner representative identified in the Bid Documents in writing to request a debriefing within sixty (60) days from the date of the notification of award.

24. BID DISPUTE PROCEDURE

In the event that a Bidder wishes to review the decision of the Board in respect of any material aspect of the Request For Tender process, the Bidder shall submit a protest in writing to the Board to the attention of the Supervisor – Procurement within ten (10) days of the closing date of the Tender.

Any protest in writing shall include the following:

- a) a specific identification of the provision and/or procurement procedure that is alleged to have been breached;
- b) a specific description of each act alleged to have breached the procurement process;
- c) a precise statement of the relevant facts;
- d) an identification of the issues to be resolved;
- e) the Bidder's arguments and supporting documentation;
- f) the Bidder's requested remedy.

25. EXAMINATION OF SITE & SITE VISIT

Location: Good Shepherd Catholic School, 4 Edith Street, Thamesville, ON.

Instructions: Report to the Main Office to sign-in at the time listed in this RFT

Contact: Paul Lernout - Cell:519-360-6262

This is a MANDATORY SITE VISIT. Only contractors who attend the site visit will be permitted to submit a bid response. Attendance will be taken and will form part of the Bid Documents. Representatives of the Owner and Consultant will be in attendance.

In submitting a bid, it will be assumed that the bidders have carefully examined the drawings and have included in the bid price the complete cost of the work contemplated by the drawings and specifications and other bid documents.

26. TIMING OF PROJECT

The schedule for the completion of the project is:

- Commencement no earlier than June 28, 2019.
- Substantial Performance no later than August 23, 2019.

Work is to be completed during normal business hours. Working outside of school hours, including daytime access during weekends, holidays, March break, etc. shall be at the sole discretion of the SCCDSB's Project Manager.

27. INVOICING & PAYMENT

The Board shall pay by electronic funds transfer (EFT), P-Card, or cheque within thirty (30) days after the receipt of a proper invoice. Invoices will be reviewed and certified by the Board's Consultant, if applicable, before the invoice is processed for payment. Invoices must include all back-up material for time and material charges, disbursements, and other fees. Please make reference to the Purchase Order number

on the invoice.

Note: Invoices should reflect a 10% holdback (final construction cost) which will be retained by Board through substantial completion of the project.

28. TAXES

Include in Bid all Taxes and all other Customs Duties and Excise Taxes which are in force at Bid date as detailed in General Conditions. Harmonized Sales Tax (H.S.T.) is **not** to be included in the bid. The H.S.T. amount and the Bidder's **H.S.T. Registration Number** are to be indicated on the Bid Form in the spaces provided.

29. CHANGE NOTICES, CHANGE ORDERS

The following fee percentage and overhead charges shall be applied to additional work ordered by the Board:

- For work carried out by the Contractor's own forces – 10% Overhead & 5% Profit
- For work carried out by Subcontractors – 5% Overhead & 5% Profit
- Credits - 0% Overhead and 0% Profits

30. PROJECT SPECIFIC REQUIREMENTS

Any and all damages to facilities while under the control of the contractor shall be repaired at the contractor's cost. Please be advised that the Owner has a No Smoking Requirement on the Owners' property. Contractors shall provide their own washroom facilities for their employees; board washrooms will be off limits to the contractor's employees. Contractors are requested to ensure that employees and suppliers are advised of these Requirements. Contractor shall remove rubbish and debris from the site on a daily basis or as directed by the Board. On completion of the work, all debris shall be removed; the floor shall be thoroughly cleaned and swept; the site shall be left in a tidy condition (construction clean). Do not use the Board's equipment or facilities for cleaning or for any reason.

31. SUBCONTRACTORS

The successful Proponent(s) may not, at any time, subcontract any portions of its contract with the Board nor shall it assign the contract without the written permission of the Board. The successful Proponent(s) must not, at any time, change subcontractors approved by the Board without the written permission of the Board.

32. GENERAL TERMS AND CONDITIONS

The issuance of this tender shall not constitute an obligation on the part of the Board to any proponent who submits a bid

The laws of the Province of Ontario shall govern any dispute occasioned as a result of the performance or non-performance and/or workmanship of a contract issued pursuant to the bid and any dispute arising out of the issuance of and response to this bid.

All SCCDSB policies, procedures and regulations must be adhered to by the successful bidder(s).

Some of the Board sites are equipped with video surveillance cameras.

The successful proponent(s) is obliged to cooperate with all recycling and environmental procedures and initiatives established by government, the Board and each school.

The successful bidder(s)' employees and contracted staff shall not be considered SCCDSB employees and shall not represent themselves as an agent of the SCCDSB nor be eligible for any of the benefits provided to SCCDSB employees.

The SCCDSB reserves the right to demand the removal of any successful bidder's employees or contracted staff engaged in this contract if, in the SCCDSB's opinion, their conduct has been of an unacceptable nature.

The successful bidder(s) will be responsible for ensuring that regular supervision is maintained over all working personnel. It is the bidder's responsibility to ensure that all their activities are properly coordinated with the SCCDSB's operations and modify assignments as required.

This tender document is being issued pursuant to the SCCDSB's Purchasing Policies and Procedures.

The acceptance of the bid by the successful proponent(s) and the award of the contract contemplated by this bid document may be subject to approval of the Board of Trustees.

33. **BONDING**

On bids exceeding \$100,000.00 (inclusive of all taxes) the following tender security / bonding is required and must accompany the bid:

- Agreement to Bond: 50% Performance and 50% Labour and Material
- Bid Bond: 10% of the bid price, payable to the St. Clair Catholic District School Board

If the bid amount is greater than \$100,000 and less than \$500,000 (inclusive of all taxes) the Surety or Bid Bond may be provided in the form of an irrevocable letter of credit, a certified cheque, or money order payable to the Board in the value of 10% of the bid amount.

Only bond and agreements to bond issued by a licenced Canadian surety company authorized to do business in the Province of Ontario will be accepted. Upon request, the successful Bidder will be required to present the bonds to the Purchasing Department. Failure to provide the proper surety to the Board upon award will result in rejection of that Bid. The cost of bonding shall be included in the Bid price and identified on the Bid Form, if applicable

34. **INSURANCE**

Contractor must maintain, at the Contractor's expense for the entire term of the Contract or as otherwise required. All insurance as set out below:

- The successful Contractor shall provide the Board with proof of insurance for Comprehensive General Liability and Property Damage with a limit of not less than **\$5,000,000.00 (five million dollars)** included in the bid submission.
- The successful Contractor shall provide the Board with proof of insurance for Motor Vehicle Public Liability and Property Insurance on all owned and rented equipment with a limit of not less than **\$2,000,000.00 (two million dollars)** included in the bid submission.
- The Contractor agrees to indemnify, hold harmless, and defend the Board from and against any and all liability for loss, damage and expense, which the Board may suffer or for which the Board may be held liable by reason of injury (including death) or damage to any property arising out of negligence on the party of the proponent or any of its representatives, employees, or subcontractors in the execution of the work performed or by way of ownership or operation of an automobile.

- The successful Contractor shall provide the Board with a complete certified copy of all policies. Copies of renewed policies must be provided to the Board on or before the policy renewal date for projects that extend past the original policy term or for multi-year contracts.
- The successful Contractor must name the St. Clair Catholic District School Board as additional insured on their insurance policies.

35. WORKPLACE SAFETY INSURANCE BOARD (WSIB)

Contractor must furnish a copy of Workplace Safety and Insurance Board Clearance Certificate of good standing, "Section 748" of the Workplace Safety and Insurance Act included in the bid submission.

36. PERMITS

The Board will apply and pay for a building permit if applicable. The contractor is to obtain all other permits as required to complete the project, including but not limited to ESA, hot work permit etc.

37. MEETINGS

A Post Bid Meeting may be convened and chaired by the Board who will invite Contractor and his major Subcontractors to review the Contract Documents and Bid submitted. This meeting will be prior to the Board issuing a Letter of Intent or Contract. This meeting does not constitute or infer any contract award to the proposed contractor or any other contractor, nor that will the project proceed.

During the course of Work, scheduled progress meetings may be required at the call of the Project Leader.

38. GUARANTEE

The guarantee shall be for a period of 1 year from and after completion of the entire job and acceptance thereof by the Board unless a different period of time is specified with the Board's approval. The Contractor's guarantee shall cover all work under the Contract whether or not any portion or trade has been sublet.

The Contractor agrees to correct promptly, at the Contractor's own expense, defects or deficiencies in the Work which appear prior to and during the period of guarantee, or such longer periods as may be specified for certain products or work.

If the Contractor fails to make any replacements or repairs required hereunder, after notice from the Board and reasonable opportunity to do so, the Board may have such work done at Contractor's expense, including all necessary labour costs in connection therewith. Board shall inform Contractor in advance of the approximate cost of such work to be done by the Board.

39. SCHEDULE

The Contractor will be required to perform the work in accordance with the Schedule dates provided in 26. Timing of Project. Ordering of major and long delivery items shall begin immediately upon successful bidder's receipt of contract award. The Contractor will provide a construction schedule within five (5) days of being awarded the project.

Time is of the essence. Bidders are to include adequate manpower, overtime and shift work necessary to meet or improve the schedule, and to make up any time lost to weather or normal delays. Include travel,

room and board costs for out of town workers, shop overtime and other premiums to expedite material and equipment, shipping premiums and any incentive costs required to meet the schedule.

40. CONTRACTED SERVICES PROGRAM

Contractors performing work on Board property must complete the Contracted Services Program. The Contracted Services Program is a joint program with Lambton Kent District School Board. This program has three basic components that **must** be met before the bid is awarded. Contractors who cannot meet the minimum requirements of this program will not be awarded this tender. Program information can be found on the Board's web site at www.st-clair.net or through the Board contact identified previously in this document. If the contractor has already been pre-qualified by LKDSB they must provide proof of completion. Identification badges can be used on SCCDSB or LKDSB property. All Insurance and WSIB certificates must be up to date under the Contracted Services Program.

41. HEALTH and SAFETY

The Occupational Health and Safety Act describes the responsibilities of an employer. The Board requires Contractors to maintain procedures, training, and enforcement so that the responsibilities are carried out in the workplace. The Contractor shall abide by and strictly adhere to the regulations and conditions set out and laid down by the most current versions of the Occupational Health and Safety Act. All staff employed or hired by the Contractor and working on the Board's premise **MUST** be trained in WHMIS in accordance with Occupational Health and Safety Act and Regulations. They **MUST** adhere to all of the Board's Health and Safety Procedures and Guidelines and to Municipal By-Laws.

Contractor will submit proof of its health and safety program, procedures and training as detailed above upon request by the Board.

The Contractor shall appoint a Competent Person as the Supervisor of this project. The Competent Person shall be as defined in Section 1 of the Occupational Health and Safety Act.

The successful Contractor shall conform to the Ontario "Occupational Health and Safety Act" and all regulations made under said act and assume full responsibility for contraventions of same.

All workplace injuries or accidents on Board property **MUST** be reported by the Contractor to the Board's representative within 24 hours.

Any workplace injury that is defined under the Occupational Health and Safety Act as a "Critical Injury" must be reported to the Board's representative **IMMEDIATELY**.

42. DESIGNATED SUBSTANCES

The contractor shall conduct work in recognition of the most current regulations related to Designated Substances. The contractor is required to review the site specific designated substances report to ascertain potential for exposure to designated materials and notify the board of instances where the scope of work under this contract will require remediation. If the report does not schedule designated materials in the attached report and should the contractor uncover material which is believed to be asbestos, work is to cease immediately and the Board staff are to be contacted immediately.

43. SAFE SCHOOL PROCEDURES

Contractor's staff is required to report to the main office of the site where work will be carried out during regular school hours and notify the school office staff of the purpose of the visit. The Contractor is required to adhere to all school specific procedures if applicable.

It is the responsibility of the Contractor's staff to sign in and sign out of the Log Book, which is located in the main office area, while performing their duties.

The following information must be recorded in a legible manner:

Date
Company Name
Employee Name
Employee Signature
Reason for Visit
Time Entering Building
Time Leaving Building

44. HOISTING, SCAFFOLDS, ELEVATED WORK PLATFORMS

The Contractor is responsible for all hoisting and other equipment necessary to facilitate their work.

45. TEMPORARY POWER

A source of electric power will be designated by the Board. The Board will allow a tie-in connection with fuse or breaker protection for the Contractor's estimated load requirements. The Contractor must provide the power connections and all extensions from the point to the job site. All electrical connections and extensions must meet ESA requirements and must be approved by the Board. The Contractor's estimated load requirements must not be exceeded without the Owner's permission.

46. NOISE AND TRAFFIC CONTROL

Bidders shall comply with all applicable **noise by-laws** (or local requirements governing same) and traffic routing that may be in effect during the life of the Project.

This **may** limit some activities to restricted time periods. Where the schedule requires for after hour work, the Contractor shall include all costs associated with obtaining the necessary permits to work such time periods.

The Contractor shall be responsible for all costs associated with providing a traffic officer as necessary to facilitate construction.

47. SITE ACCESS AND EGRESS

Contractors will be required to sign out a master key and will be assigned an access code for the alarm system. Successful Contractor will be responsible for building security during working hours and locking up the facility at night, which includes setting the alarm.

Any false alarms generated by the Contractor's workforce will result in a back charge for the costs incurred to the Board.

The Contractor shall make good any damage to roads, curbs, sidewalks, fencing, or grass damaged by vehicles or equipment during the course of construction.

48. PARKING

Contractors must park within the designated areas and allow for provisions to and from the designated parking area onto the job site.

49. CONTRACTOR'S PERSONNEL

The Contractor shall, at its own expense, provide all the personnel required to take a proactive role in managing the project as it relates to their work and its coordination with other trades. This will include but is not limited to the following:

- Competent supervision of the work of the Contract and coordination with the work of other Subcontractors. This includes being responsible for and properly supervising any subcontractors of this subcontractor.
- All layout work required to complete the work of the trade contract.
- Competent supervision of the work of the trade contract to ensure work is done in accordance with the OHSA and any other applicable regulations.
- Expediting the procurement of material and equipment to ensure delivery by their required dates.
- Submission of Requests for Information where required in a timely manner and wherever possible providing the Board with information to assist in the answering of these requests.
- Submission in a timely manner of all required shop drawings and samples and assistance to the Board required to obtain approvals to suit the schedule. All shop drawings are to be reviewed by the Contractor prior to submitting for approval.
- Attendance at all construction coordination meetings when requested by the Board.
- Provision of all necessary information requested by the Board for cost control and billing purposes.
- Inspection of the work of the Trade Contract for defects and deficiencies and cooperation with the Board and other inspection authorities to allow their inspections to take place.
- Submission of pricing for all changes to the work within five (5) working days after receipt of change documentation including the breakdown and backup necessary to allow checking and approval.

50. ACCESSIBILITY FOR ONTARIANS WITH DISABILITIES ACT

The Purchaser is committed to the highest possible standards for accessibility. Proponent(s) must be capable to recommend and deliver, as appropriate for each Deliverable, accessible and inclusive Services consistent with the Ontario Human Rights Code (OHRC), the Ontarians with Disabilities Act, 2001 (ODA) and Accessibility for Ontarians with Disabilities Act, 2005 (AODA) and its regulations in order to achieve accessibility for Ontarians with disabilities.

In accordance with Ontario Regulation 429-07 made under the Accessibility for Ontarians with Disabilities Act, 2005 (Accessibility Standards for Customer Service), the Purchaser has established policies, practices and procedures governing the provision of its services to persons with disabilities.

Proponents are required to comply with the Purchaser's accessibility standards, policies, practices, and procedures, which may be in effect during the Term of the Agreement and which apply to the Deliverables to be provided by the Proponent.

51. CANADA'S ANTI-SPAM LEGISLATION

Please note that vendors are required to comply with all applicable laws, including CASL, in providing goods or services to the Board. This also extends to communications sent on the Boards behalf. The successful proponent(s) will be required to indemnify the Board for any failure by the successful proponent(s) to comply with CASL, to the extent that the successful proponent(s) action, or inaction, could expose the Board to liability.

52. CONFIDENTIAL INFORMATION

All correspondence, documentation, and information of any kind provided to any Proponent in connection with or arising out of this Request for Tender or the acceptance of any Bid:

- Remains the property of the Purchaser and shall be removed from the Purchaser's premises only with the prior written consent of the Purchaser.
- Must be treated as confidential and shall not be disclosed except with the prior written consent of the Purchaser.
- Must not be used for any purpose other than for replying to this RFT and for the fulfilment of any related subsequent agreement.
- Must be returned to the Purchaser upon request.

Except as provided otherwise in this request, or as may be required by Applicable Laws, the Purchaser shall treat the Proponents' Proposals and any information gathered in any related process as confidential, provided that such obligation shall not include any information that is or becomes generally available to the public other than as a result of disclosure by the Purchaser.

During any part of this Request for Tender process, the Purchaser or any of its representatives or agents shall be under no obligation to execute a confidentiality agreement.

All correspondence, documentation, and information provided in response to or because of this RFT may be reproduced for the purposes of evaluating the Proponent's Bid Submission.

If a portion of a Proponent's Bid Submission is to be held confidential, such provisions must be clearly identified in the Bid.

The Purchaser reserves the right to require any Proponent to enter into a non-disclosure and/or confidentiality agreement satisfactory to the Purchaser.

53. MUNICIPAL FREEDOM OF INFORMATION AND PROTECTION OF PRIVACY ACT

The *Municipal Freedom of Information and Protection of Privacy Act* (Ontario) applies to information provided by Proponents. A Proponent should identify any information in its Quotation or any accompanying documentation supplied in confidence for which confidentiality is to be maintained by the Purchaser. The confidentiality of such information will be maintained by the Purchaser, except as otherwise required by law or by order of a court, tribunal, or the Ontario Privacy Commissioner.

By submitting a Bid, including any Personal Information requested in this RFT, Proponents agree to the use of such information for the evaluation process, for any audit of this procurement process, and for contract management purposes.

54. TRADE AGREEMENTS

Proponents should note that procurements coming within the scope of either Chapter 5 of the Canadian Free Trade Agreement, Chapter 19 of the Comprehensive Economic and Trade Agreement or any other

applicable agreement not listed herein are subject to such agreements, although the rights and obligations of the parties shall be governed by the specific terms of this RFT.

55. WORKPLACE HAZARDOUS MATERIALS INFORMATION SYSTEM

The Proponent should provide Workplace Hazardous Materials Information System (WHMIS) material safety data sheets (MSDS) for all Services. Additionally, the Proponent should provide the Purchaser's personnel WHMIS training, as it relates to the Services, in accordance with the Ontario Occupational Health and Safety Act.

56. VENDOR PERFORMANCE

Where the Contractor fails to comply with any of its obligations under the Contract, the Board may issue a notice setting out the manner and time-frame for rectification. Within seven (7) Business Days of receipt of that notice or in a timeframe as otherwise agreed to, the Contractor shall either: (a) comply with that rectification notice; or (b) provide a rectification plan satisfactory to the Board. If the Contractor fails to either comply with that rectification notice or provide a satisfactory rectification plan, the Board may immediately terminate the Contract. Where the Contractor has been given a prior rectification notice, the same subsequent type of non-compliance by the Contractor may allow the Board to immediately terminate the Contract and result in the suspension of bidding privileges to the Board for up to two years at the sole unfettered discretion of the Board.

57. TERMINATION OF CONTRACT

Either party may terminate the Agreement on written notice to the other where such other party neglects or fails to perform or observe any material term or obligation of the Agreement and such failure has not been cured within 30 Days of written notice being provided.

The Board shall be entitled to terminate the Agreement, without liability, cost, or penalty:

- On written notice to the Proponent, if any proceeding in bankruptcy, receivership, liquidation, or insolvency is commenced against the Proponent or its property;
- On written notice to the Proponent, if the Proponent makes an assignment for the benefit of its creditors, becomes insolvent, commits an act of bankruptcy, ceases to carry on its business or affairs as a going concern, files a notice of intention or a proposal, or seeks any arrangement or compromise with its creditors under any statute or otherwise;
- Or at any time, without cause, by giving the Proponent at least 60 Days written notice.

END OF INSTRUCTIONS TO BIDDERS

APPENDIX A: Agreement of Terms

I hereby acknowledge and agree that I have read and completed all the preceding Contract Terms and Conditions and Appendices.

I understand it is the SCCDSB's intention that this tender and the successful proponent(s)'s returned tender submission will form the basis of the proposed contract. All of the terms and conditions of this Tender must be accepted by the proponent(s) and incorporated into the proponent(s) Tender submission. It is the SCCDSB's intention to use a CCDC2-2008 Stipulated Price Contract when establishing a contract with the successful proponent(s).

Acknowledgement of Addenda _____ through _____

This page must be signed below and returned with your submission for your tender to be accepted.

I/We the undersigned are duly authorized to execute this Bid Submission on behalf of:

COMPANY: _____

NAME/ TITLE: _____

SIGNATURE: _____

WITNESS NAME / TITLE: _____

WITNESS SIGNATURE: _____

ADDRESS: _____

EMAIL: _____

TELEPHONE: _____

DATE: _____ SEAL:

Please refer to Appendix C: Bidder's Response Guide to ensure you include all necessary documentation with your bid submission

APPENDIX B: Bid Form

Submitted By: _____

To:

St. Clair Catholic District School Board
642-CP1917 Playground Asphalt Replacement Project
Good Shepherd Catholic School, Thamesville, ON

B1. Bid Price

The Drawings, Specifications and other Contract Documents for this Project have been examined, as well as the premises and job site conditions affecting the work. The undersigned hereby offers to complete the work in accordance with the Contract Documents for the following bid price, except as defined below for HST:

_____ Dollars (\$ _____)

in Canadian funds EXCLUDING HST. HST will be added to the bid price.

In submitting this Bid, the undersigned recognizes and accepts the right of the Owner to accept any Bid, which is deemed the most advantageous to the Owner, (or any part thereof), at the price submitted, or to reject any or all Bids. Acceptance of the Bid and/or award of the contract is subject to the approval of the Board.

In the event that a discrepancy arises between the written bid price and the associated numerical price, the written bid price will be deemed to be correct.

B2. Harmonized Sales Tax (HST)

The bidder shall not include the applicable HST in the bid price. The successful contractor will indicate on each application for payment as a separate amount the appropriate HST the Owner is obliged to pay.

B3. Cash Allowances

1. Include a Stipulated Sum of Ten Thousand Dollars (\$10,000.00) to cover over the following items from which the Consultant shall direct payment for services, labour, and material.
 - a. Provisional Cash Allowance
 - b. Owner's Provisional Allowance
2. Include a Stipulated Sum of Five Thousand Dollars (\$5,000.00) to cover costs associated with various testing.

Time and Materials rates to be applied against Cash Allowance work. Final reconciliation will adjust the cash allowance as credit to the SCCDSB for unexpended amounts and extra to the contractor for over expenditure. The contractor shall mark-up sub-trade time and materials billing for this portion of work at 10% only.

B4. Separate Prices

It is accepted that the intent of separate prices is to allow the Owner to select a separate scope of work at a price which is declared below, and solely at the owner's discretion.

The following price has not been included in the Base Bid amount. The following prices, if accepted by the owner, shall include all labour, material, tools, equipment, overhead and profit, but exclude H.S.T. No other cost consideration shall be added to the contract for the scope of this work if accepted by the owner.

Separate Price #1:

Asphalt Replacement at Basketball Courts as shown in Drawing A101

\$ _____

B5. List of Subcontractors

Asphalt _____

B6. Project Superintendent / Supervisor

The Owner requires the General Contractor provide a full time site supervisor for the duration of the project. A minimum of 5 years supervisory experience is required. List proposed personnel and their experience in the table below. Supervisory experience with firms other than the Bidder is acceptable to include on the list. The General Contractor shall indicate the person chosen in writing to the Owner within 5 days of contract award.

Name	Firm/Position	Qualifications/ Experience

APPENDIX C: Bidder's Response Guide

Each bid submission should be structured using only the criteria identified in this bid document.

1. A signed copy of APPENDIX A: Agreement of Terms **must** be included for your bid submission to be accepted
2. A completed copy of APPENDIX B: Bid Form **must** be included in your bid submission.
3. Proof of WSIB Coverage and proof of insurance **must** be included in your bid submission.
4. Bidders **must** provide one signed copy of the bid documents.
5. Supplemental material will not qualify as substitutes for direct responses to the bid's requirements, except for specifically requested material.
6. The successful contractor must be prequalified under the contracted services program before an award is made.
7. The work shall conform to the latest standards and codes listed in the Ontario School Code, National School Code, and all applicable provincial and municipal codes as of the date of this project in case of conflict or discrepancy; the most stringent requirement shall apply.
8. Contractor shall apply for and obtain all required SCCDSB or Provincial licenses as necessary.
9. Pay all fees and obtain all permits (excluding building permit). Provide authorities with plans and information for acceptance certificates. Provide inspection certificates as evidence that work conforms to requirements of Authority having jurisdiction.



Tender 642-CP1917
Playground Asphalt Replacement
Good Shepherd Catholic School
4 Edith Street, Thamesville, ON

APPENDIX D: Scope of Work and Specifications

Section No.	Title	No of Pages
DIVISION 01 - GENERAL REQUIREMENTS		
00 80 00	Supplementary Conditions	8
00 90 10	Substitution Request Form	2
01 00 00	General Requirements	4
01 21 00	Allowances	1
01 23 20	Separate Prices	1
01 25 00	Contract Modifications	2
01 29 00	Payment Procedures	2
01 31 00	Project Management and Coordination	1
01 31 19	Project Meetings	1
01 32 16	Construction Schedule	2
01 33 00	Submittal Procedures	3
01 35 29	Health and Safety Requirements	2
01 35 43	Environmental Procedures	1
01 41 00	Regulatory Requirements	1
01 45 00	Quality Control	1
01 51 00	Temporary Utilities	1
01 52 00	Construction Facilities	1
01 56 00	Temporary Barriers and Enclosures	1
01 61 00	Common Product Requirements	3
01 71 00	Examination and Preparation	1
01 73 00	Execution	2
01 74 11	Cleaning	2
01 78 00	Closeout Procedures & Submittals	3
DIVISION 02		
02 41 99	Demolition	2
DIVISION 03 - 30 NOT USED		
DIVISIONS 31 – EARTHWORK		
31 11 10	Clearing and Grubbing	1
DIVISIONS 32 – EXTERIOR IMPROVEMENTS		
31 91 19	Topsoil Placement & Fine Grading	3
32 91 19	Hydroseed	4

END OF SECTION

The Standard Construction Document for Stipulated Price Contract, 2008 English version, consisting of the Agreement Between *Owner* and *Contractor*, Definitions, and General Conditions of the Stipulated Price Contract, Parts 1 to 12 inclusive, governing same is hereby made part of these *Contract Documents*, with the following amendments, additions and modifications for the above named Project. Where these amendments, additions, and modifications specifically reference a change to the Agreement, Definitions, or General Conditions, these amendments, additions and modifications shall govern.

1 **ARTICLE A-5 PAYMENT:**

- .1 Insert in Paragraph 5.1 "Ten Percent (10%)"
- .2 Insert in Paragraph 5.3 "Bank of Canada"

2 **ARTICLE A-6 RECEIPT OF AND ADDRESSES FOR NOTICES IN WRITING**

- .1 Delete Article A-6.1 and substitute new article 6.1:
 - 6.1 *Notices in Writing* between the parties or between them and the *Consultant* shall be considered to have been received by the addressee on the date of receipt if delivered by hand or by commercial courier or if sent during normal business hours by fax and addressed as set out below. Such *Notices in Writing* will be deemed to be received by the addressee on the next business day if sent by fax after normal business hours or if sent by overnight commercial courier. Such *Notices in Writing* will be deemed to be received by the addressee on the fifth *Working Day* following the date of mailing, if sent by pre-paid registered post, when addressed as set out below. An address for a party may be changed by *Notice in Writing* to the other party setting out the new address in accordance with this Article.

3 **ARTICLE A-7 LANGUAGE OF THE CONTRACT**

- .1 Refer to sentence 7.1, strike out "French"

4. **DEFINITIONS**

- .1 Add the following definition:
 - 27. **Submittals**
Submittals are documents or items required by the *Contract Documents* to be provided by the *Contractor*, such as:
 - *Shop Drawings*, samples, models, mock-ups to indicate details or characteristics, before the portion of the *Work* that they represent can be incorporated into the *Work*; and
 - As-built drawings and manuals to provide instructions to the operation and maintenance of the *Work*.

5. **PART 1 GENERAL PROVISIONS**

- .1 Where a General Condition or paragraph of the General Conditions of the Stipulated Price Contract is deleted by these Supplementary Conditions, the numbering of the remaining General Conditions or paragraphs shall remain unchanged, and the numbering of the deleted item will be retained, unused.

6. **GENERAL PROVISIONS**

- .1 Where a General Condition or paragraph of the General Conditions of the Stipulated Price Contract is deleted by these Supplementary Conditions, the numbering of the remaining General Conditions or paragraphs shall remain unchanged, and the numbering of the deleted item will be retained, unused.

7. GC 1.1 CONTRACT DOCUMENTS

- .1 Add to the end of subparagraph 1.1.2.2

Except where the *Consultant* shall be indemnified as a third party beneficiary as provided in subparagraphs 9.2.7.4, 9.5.3.4 and in 12.1.3.

- .2 Add new subparagraph 1.1.7.5:

1.1.7.5 In case of discrepancies, noted materials and annotations shall take precedence over graphic indications in the *Contract Documents*.

- .3 Delete paragraph 1.1.8 and substitute new paragraph 1.1.8:

1.1.8 The *Owner* shall provide the *contractor* digital copies (PDF format) of the *Contract Documents* and all administrative documents such as *Change Orders*, *Change Directives*, and *Supplemental Instructions*. All required hardcopies of the *Contract Documents* or part thereof including additional copies of administrative documents, shall be at the expense of the contractor.

8. GC 2.2 ROLE OF THE CONSULTANT

- .1 Add to the end of paragraph 2.2.9

The *Owner* and the *Contractor* shall waive any claims against the *Consultant* arising out of the making of such interpretations and findings made in accordance with paragraphs 2.2.7., 2.2.8. and 2.2.9.

- .2 Delete paragraph 2.2.14 and substitute new paragraph 2.2.14:

2.2.14 The *Consultant* will review and take appropriate action upon *Shop Drawings*, samples and other *Contractor's* submittals which are provided in accordance with the *Contract Documents*.

9. GC 2.4 DEFECTIVE WORK

- .1 Add new subparagraph 2.4.1.1

2.4.1.1 The *Contractor* shall rectify, in a manner acceptable to the *Owner* and the *Consultant*, all defective work and deficiencies throughout the *Work*, whether or not they are specifically identified by the *Consultant*.

- .2 Add new subparagraph 2.4.1.2

2.4.1.2 The *Contractor* shall prioritize the correction of any defective work which, in the sole discretion of the *Owner*, adversely affects the day to day operation of the *Owner*.

10. GC 3.1 CONTROL OF THE WORK

- .1 Add new paragraph 3.1.3

3.1.3 Prior to commencing individual procurement, fabrication and construction activities, the *Contractor* shall verify, at the *Place of the Work*, all relevant measurements and levels necessary for proper and complete fabrication, assembly and installation of the *Work* and shall further carefully compare such field measurements and conditions with the requirements of the *Contract Documents*. Where dimensions are not included or contradictions exist, or exact locations are not apparent, the *Contractor* shall immediately notify the *Consultant* in writing and obtain written instructions from the *Consultant* before proceeding with any part of the affected work.

11. GC 3.4 DOCUMENT REVIEW

.1 Delete paragraph 3.4.1 and substitute new paragraph 3.4.1

3.4.1 The *Contractor* shall review the *Contract Documents* and shall report promptly to the *Consultant* any error, inconsistency or omission the *Contractor* may discover. Such review by the *Contractor* shall comply with the standard of care described in paragraph 3.14.1 of the *Contract*. Except for its obligation to make such review and report the result, the *Contractor* does not assume any responsibility to the *Owner* or to the *Consultant* for the accuracy of the *Contract Documents*. The *Contractor* shall not be liable for damage or costs resulting from such errors, inconsistencies, or omissions in the *Contract Documents*, which the *Contractor* could not reasonably have discovered. If the *Contractor* does discover any error, inconsistency or omission in the *Contract Documents*, the *Contractor* shall not proceed with the work affected until the *Contractor* has received corrected or missing information from the *Consultant*.

12. GC 3.7 SUBCONTRACTORS AND SUPPLIERS

.1 Add new paragraph 3.7.7

3.7.7 After signing of the *Contract*, no deviation from the list of *Subcontractors* or *Suppliers* shall be made during the progress of the *Work* of the *Contract* without the *Owner's* written permission.

13. GC 3.8 LABOUR AND PRODUCTS

.1 Add new paragraph 3.8.4

3.8.4 The *Contractor* is responsible for the safe on-site storage of *Products* and their protection (including *Products* supplied by the *Owner* and other contractors to be installed under the *Contract*) in such ways as to avoid dangerous conditions or contamination to the *Products* or other persons or property and in locations at the *Place of the Work* to the satisfaction of the *Owner* and the *Consultant*. The *Owner* shall provide all relevant information on the *Products* to be supplied by the *Owner*.

14. GC 3.10 SHOP DRAWINGS

.1 Add the words "AND OTHER SUBMITTALS" to the Title after SHOP DRAWINGS.

.2 Add "and *Submittals*" after the words "*Shop Drawings*" in paragraphs 3.10.1, 3.10.2, 3.10.4, 3.10.7, 3.10.8, 3.10.8.2, 3.10.9, 3.10.10, 3.10.11, and 3.10.12.

.3 Delete paragraph 3.10.3 and substitute new paragraph 3.10.3

3.10.3 Prior to the first application for payment, the *Contractor* and the *Consultant* shall jointly prepare a schedule of the dates for submission and return of *Shop Drawings* and any *Submittals*.

.4 Delete paragraph 3.10.12 and substitute new paragraph 3.10.12

3.10.12 The *Consultant* will review and return *Shop Drawings* in accordance with the schedule agreed upon, or, in the absence of such schedule, within 10 working days or such longer period as may be reasonably required.

15. PART 3 EXECUTION OF THE WORK

.1 Add new General Condition 3.14 PERFORMANCE BY CONTRACTOR

.2 Add new paragraph 3.14.1

3.14.1 In performing its services and obligations under the *Contract*, the *Contractor* shall exercise a standard of care, skill and diligence that would normally be provided by an experienced and prudent contractor supplying similar services for similar projects. The *Contractor* acknowledges and agrees that throughout the *Contract*, the *Contractor's* obligations, duties and responsibilities shall be interpreted in accordance with this standard. The *Contractor* shall exercise the same standard of due care and diligence in respect of any *Products*, personnel, or procedures which it may recommend to the *Owner*.

.3 Add new paragraph 3.14.2

3.14.2 The *Contractor* further represents, covenants and warrants to the *Owner* that:

- .1 The personnel it assigns to the *Project* are appropriately experienced;
- .2 It has a sufficient staff of qualified and competent personnel to replace its designated supervisor and project manager, subject to the *Owner's* approval, in the event of death, incapacity, removal or resignation.

16. GC 4.1 CASH ALLOWANCES

.1 Delete paragraph 4.1.4 substitute new paragraph 4.1.4

4.1.4 Where costs under a cash allowance exceed the amount of the allowance, unexpended amounts from other cash allowances shall be reallocated at the *Consultant's* direction to cover the shortfall.

.2 Delete paragraph 4.1.5 substitute new paragraph 4.1.5:

4.1.5. The net amount of any unexpended cash allowances, after providing for any reallocations as contemplated in paragraph 4.1.4, shall be deducted from the *Contract Price* by *Change Order*.

.3 Delete paragraph 4.1.7 and substitute new paragraph 4.1.7.

4.1.7 At the commencement of the *Work*, the *Contractor* shall prepare for the review and acceptance of the *Owner* and the *Consultant*, a schedule indicating the times, within the construction schedule referred to in GC 3.5, that items called for under cash allowances and items that are specified to be *Owner* purchased and *Contractor* installed or hooked up are required at the site to avoid delaying the progress of the *Work*.

.4 Add new paragraph 4.1.8:

4.1.8 The *Owner* reserves the right to call, or to have the *Contractor* call, for competitive bids for portions of the *Work*, to be paid for from cash allowances.

17. GC 6.2 CHANGE ORDER

.1 Add new paragraph 6.2.3

6.2.3 The value of changes to the *Work* shall be determined by one of the following agreed upon methods:

- (A) Estimate and acceptance of itemized lump sum for additional *Work* with overhead and profit applied as a percentage as listed below:
- .1 10% overhead and 5% profit for net cost of *Work* done by Contractors own forces
 - .2 5% overhead and 5% profit for net cost *Work* done by *Subcontractors*
 - .3 0% overhead and profit on credits
- (B) Unit prices as set out in the contract or subsequently agreed upon, with adjustments to the *Contract Price* based on net quantity difference from original quantity. Overhead and profit applied as a percentage as listed below:
- .1 10% overhead and 5% profit for net cost of *Work* done by Contractors own forces
 - .2 5% overhead and 5% profit for net cost *Work* done by *Subcontractors*
 - .3 0% overhead and profit on credits

18. GC 6.4 CONCEALED OR UNKNOWN CONDITIONS

.1 Add new paragraph 6.4.5

6.4.5 The *Contractor* confirms that, prior to bidding the *Project*, it carefully investigated the *Place of the Work* and applied to that investigation the degree of care and skill described in paragraph 3.14.1, given the amount of time provided between the issue of the bid documents and the actual closing of bids, the degree of access provided to the *Contractor* prior to submission of bid, and the sufficiency and completeness of the information provided by the *Owner*. The *Contractor* is not entitled to compensation or to an extension of the *Contract Time* for conditions which could reasonably have been ascertained by the *Contractor* by such careful investigation undertaken prior to the submission of the bid.

19. GC 6.5 DELAYS

.1 Delete the period at the end of paragraph 6.5.1, and substitute the following words:

“, but excluding any consequential, indirect or special damages.”

.2 Add new subparagraph 6.5.6.

6.5.6 If the *Contractor* is delayed in the performance of the *Work* by an act or omission of the *Contractor* or anyone employed or engaged by the *Contractor* directly or indirectly, or by any cause within the *Contractor's* control, then the *Contract Time* shall be extended for such reasonable time as the *Consultant* may decide in consultation with the *Contractor*. The *Owner* shall be reimbursed by the *Contractor* for all reasonable costs incurred by the *Owner* as the result of such delay, including all services required by the *Owner* from the *Consultant* as a result of such delay by the *Contractor* and, in particular, the cost of the *Consultant's* services during the period between the date of *Substantial Performance of the Work* stated in Article A-1 herein as the same may be extended through the provisions of these General Conditions and any later, actual date of *Substantial Performance of the Work* achieved by the *Contractor*.

20. GC 6.6 CLAIMS FOR A CHANGE IN CONTRACT PRICE

.1 In paragraph 6.6.5, Add the words “as noted in paragraph 6.6.3” after the words “of the claim” and add the words “and the *Consultant*”, at the end of paragraph 6.6.5.

21. GC 8.2 NEGOTIATION, MEDIATION AND ARBITRATION

.1 Add new paragraph 8.2.9

- 8.2.9 Within five days of receipt of the notice of arbitration by the responding party under paragraph 8.2.6, the *Owner* and the *Contractor* shall give the *Consultant* a written notice containing:
- a) a copy of the notice of arbitration
 - b) a copy of supplementary conditions 8.2.9 to 8.2.14 of this *Contract*, and;
 - c) any claims or issues which the *Contractor* or the *Owner*, as the case may be, wishes to raise in relation to the *Consultant* arising out of the issues in dispute in the arbitration

.2 Add new paragraph 8.2.10

- 8.2.10 The *Owner* and the *Contractor* agree that the *Consultant* may elect, within ten days of receipt of the notice under paragraph 8.2.9, to become a full party to the arbitration under paragraph 8.2.6 if the *Consultant*:
- a) has a vested or contingent financial interest in the outcome of the arbitration;
 - b) gives the notice of election to the *Owner* and the *Contractor* before the arbitrator is appointed;
 - c) agrees to be a party to the arbitration within the meaning of the rules referred to in paragraph 8.2.6, and,
 - d) agrees to be bound by the arbitral award made in the arbitration.

.3 Add new paragraph 8.2.11

- 8.2.11 If an election is made under paragraph 8.2.10, the *Consultant* may participate in the appointment of the arbitrator and, notwithstanding the rules referred to in paragraph 8.2.6, the time period for reaching agreement on the appointment of the arbitrator shall begin to run from the date the respondent receives a copy of the notice of arbitration.

.4 Add new paragraph 8.2.12

- 8.2.12 The arbitrator in the arbitration in which the *Consultant* has elected under paragraph 8.2.10 to become a full party may:
- a) on application of the *Owner* or the *Contractor*, determine whether the *Consultant* has satisfied the requirements of paragraph 8.2.10, and;
 - b) make any procedural order considered necessary to facilitate the addition of the *Consultant* as a party to the arbitration.

.5 Add new paragraph 8.2.13

- 8.2.13 The provisions of paragraph 8.2.9 shall apply mutatis mutandis to written notice to be given by the *Consultant* to any sub-consultant;

.6 Add new paragraph 8.2.14

- 8.2.14 In the event of notice of arbitration given by the *Consultant* to a sub-consultant, the sub-consultant is not entitled to any election with respect to the proceeding as outlined in 8.2.10, and is deemed to be bound by the arbitration proceeding.

22. GC 9.1 PROTECTION OF WORK AND PROPERTY

.1 Delete subparagraph 9.1.1.1 and substitute new subparagraph 9.1.1.1

9.1.1.1 Errors in the *Contract Documents* which the *Contractor* could not have discovered applying the standard of care described in paragraph 3.14.1;

.2 Delete paragraph 9.1.2 and substitute new paragraph 9.1.2

9.1.2 Before commencing any *Work*, the *Contractor* shall determine the locations of all underground utilities and structures indicated in the *Contract Documents*, or that are discoverable by applying to an inspection of the *Place of the Work* the degree of care and skill described in paragraph 3.14.1.

23. GC 9.2 TOXIC AND HAZARDOUS SUBSTANCES

.1 Add to paragraph 9.2.6 after the word "responsible", the following new words:

or whether any toxic or hazardous substances or materials already at the *Place of the Work* (and which were then harmless or stored, contained or otherwise dealt with in accordance with legal and regulatory requirements) were dealt with by the *Contractor* or anyone for whom the *Contractor* is responsible in a manner which does not comply with legal and regulatory requirements, or which threatens human health and safety or the environment, or material damage to the property of the *Owner* or others,

.2 Add "and the *Consultant*" after the word "*Contractor*" in subparagraph 9.2.7.4.

.3 Add to paragraph 9.2.8 after the word "responsible", the following new words:

or that any toxic or hazardous substances or materials already at the *Place of the Work* (and which were then harmless or stored, contained or otherwise dealt with in accordance with legal and regulatory requirements) were dealt with by the *Contractor* or anyone for whom the *Contractor* is responsible in a manner which does not comply with legal and regulatory requirements, or which threatens human health and safety or the environment, or material damage to the property of the *Owner* or others,

24. GC 9.5 MOULD

.1 Add "and the *Consultant*" after "*Contractor*" in subparagraph 9.5.3.4.

25. GC 10.1 TAXES AND DUTIES

.1 Add new paragraph 10.1.3

10.1.3 The *Contractor's* overhead and profit shall not be included on extras or credits resulting from changes in taxes and duties.

26. GC 10.2 LAWS, NOTICES, PERMITS, AND FEES

.1 Delete paragraph 10.2.2 and substitute new paragraph 10.2.2

10.2.2 "The Owner shall obtain and pay for zoning revisions, permanent easements and rights of servitude. The Contractor shall be responsible for all permits, including the Building Permit, licenses, damage and other deposits, or certificates necessary for the performance of the Work which were in force at the date of bid closing.

.2 Delete from the first line of paragraph 10.2.5 the word, "The" and substitute the words: "Subject to paragraph 3.14.1, the".

27. 11.2 CONTRACT SECURITY

.1 Delete paragraph 11.2.1 and substitute new paragraph 11.2.1

11.2.1 The *Contractor* shall provide to the Owner the following Bonds:

- .1 A Performance Bond in the amount of Fifty percent (50%) of the total *Contract* amount covering the performance of the *Contract*, *including the requirements of GC 12.3 WARRANTY*
- .2 A Labour and Materials Bond in the amount of Fifty Percent (50%) of the Total Contract Amount.

The *Contractor* shall deliver the original bonds to the *Owner* within ten (10) days of receipt by the *Contractor* of the *Owner's* written acceptance of the Bid.

.2 Add paragraph 11.2.3

11.2.3 The premiums for such bonds shall be included in the *Contract Price*.

28. GC 12.1 INDEMNIFICATION

.1 Add new subparagraph 12.1.1.3.

12.1.1.3 The *Contractor* shall indemnify and hold harmless the *Consultant*, its agents and employees from and against claims, demands, losses, costs, damages, actions, suits, or proceedings by third parties that arise out of, or are attributable to, the *Contractor's* performance of the *Contract*, provided such claims are attributable to bodily injury, sickness, disease, or death, or to injury to or destruction of tangible property, and caused by negligent acts or omissions of the *Contractor* or anyone for whose acts the *Contractor* may be liable, and made in writing within a period of 6 years from the date of *Substantial Performance of the Work* as set out in the certificate of *Substantial Performance of the Work*, or within such shorter such period as may be prescribed by any limitation statute or the province or territory of the *Place of Work*.

29. GC 12.3 WARRANTY

.1 Delete from the first line of paragraph 12.3.2 the word, "The" and substitute the words: "Subject to paragraph 3.14.1, the".

END OF SECTION

SUBSTITUTION REQUEST FORM

- Contractor Company _____
- Sub Trade
- Supplier | Manufacturer Date _____

Bidder hereby requests acceptance of the following product or system as a substitution in accordance with provisions of Section 00 21 13 - Instructions to Bidders, and Section 00 90 00 "Substitution Procedures."

1. SPECIFIED PRODUCT OR SYSTEM

Substitution request for: _____

Specification Section No.: _____ Article | Paragraph _____

2. REASON FOR SUBSTITUTION REQUEST

PROPOSED PRODUCT

- Will reduce construction time
- Will result in cost savings
- Requested Alternative
- Is for subcontractors convenience
- Other: _____

3. PROPOSED SUBSTITUTION

Manufacturer: _____ Phone Number: _____

Product Name: _____ Model | Series: _____

Installer: _____ Phone Number: _____

Warranty: _____ Additional Info: _____

4. MANDATORY SUPPORTING DATA

- Drawings, specifications, product data, performance data, test data, and any other necessary information to facilitate review of the Substitution Request is attached
- Sample Attached

5. EFFECT OF SUBSTITUTION

Proposed substitution effects other work or trades: No Yes (if yes, explain)

Proposed substitution requires dimensional revisions or redesign of architectural, civil, structural, mechanical, electrical or other work: No Yes (if yes, explain)

6. STATEMENT OF CONFORMANCE OF REQUEST TO CONTRACT REQUIREMENTS

Submitting Contractor has investigated the proposed substitution and hereby represent that:

- A. They have personally investigated the proposed substitution and believe that it is equal to or superior in all respects to specified product, except as stated above;
- B. The proposed substitution is in compliance with applicable codes and ordinances;
- C. The proposed substitution will provide same warranty as specified for specified product;
- D. They will coordinate the incorporation of the proposed substitution into the Work, and will include modifications to the Work as required to fully integrate the substitution;
- E. They waive all future claims for added cost or time to the Contract related to the substitution, or that become known after substitution is accepted.
- F. The Architect's approval, if granted, will be based upon data submitted with this request and opinion, knowledge, information, and belief of the Architect at the time decision is rendered and Addendum is issued; and that Architect's approval therefore is interim in nature and subject to reevaluation and reconsideration as additional data, materials, workmanship, and coordination with other work are observed and reviewed.

Bidding Contractor: _____
(Name of Contractor)

Date: _____ By: _____

End of Document

Part 1 General

1.1 WORK COVERED BY CONTRACT DOCUMENTS

- .1 Work to complete site replace playground asphalt and further identified as ROA studio Inc. Project ID 19-010.

1.2 CONTRACT METHOD

- .1 Construct Work under single, stipulated price contract, CCDC2-2008

1.3 DOCUMENTS REQUIRED

- .1 Maintain at job site, one copy each document as follows:
 - .1 Contract Drawings.
 - .2 Specifications.
 - .3 Addenda.
 - .4 Reviewed Shop Drawings.
 - .5 List of Outstanding Shop Drawings.
 - .6 Change Orders.
 - .7 Other Modifications to Contract.
 - .8 Field Test Reports.
 - .9 Copy of Approved Work Schedule.
 - .10 Health and Safety Plan and Other Safety Related Documents.
 - .11 Other documents as specified

1.4 PERMITS

- .1 The Contractor shall apply and pay for all permits, including the Building Permit, licenses, damage and other deposits, or certificates necessary for the performance of the Work which were in force at the date of bid closing.

1.5 CONTRACTOR USE OF PREMISES

- .1 Limit access of construction personnel to areas of Work. Ensure construction personnel do not use occupied areas of the existing building as access to the work areas, except where prearranged with Owner.
- .2 Prohibit use of washroom and services in building by construction personnel, except where prearranged with Owner.
- .3 Smoking is prohibited everywhere on the property.
- .4 Secure work area by methods compatible with the total security established for the building.
- .5 Contractor's forces, tradesmen, workers, suppliers of subcontractors employed directly or indirectly by the Contractor will be allowed to park their vehicles in designated areas.
- .6 Obtain and pay for use of additional storage or work areas needed for operations under this Contract.

- .7 At completion of operations condition of existing work: equal to or better than that which existed before new work started.

1.6 OWNER OCCUPANCY

- .1 Portion of building not under construction will be occupied during entire construction period.

1.7 EXISTING SERVICES

- .1 Ensure that existing services are not damaged during demolition and construction. Immediately cut off and cap concealed services uncovered during work by qualified mechanical and electrical workers.
- .2 Relocate mechanical and electrical services exposed during alteration work.
- .3 Should existing services be accidentally uncovered and disrupted, notify Owner and make complete restoration immediately, and provide adequate protection to avoid further disruption until alternative means of providing permanent continuation of the services can be made.
 - .1 Rectification for work specified in the above shall be made by the Contractor at no additional cost to the Owner, if such work could have been foreseen and which has been caused by lack of proper care and protection.
 - .2 If accidental disruption is made and could not have been foreseen, the Contractor shall advise Consultant and Owner of the commencement, duration and termination dates of this work; keep a record of work hours, number of workers, tools, equipment rentals, quantities of material used, mileage, etc. to present with claim.
- .4 Unless otherwise specified, restore services on which work is performed to original condition.

1.8 SAFETY AND SECURITY DURING CONSTRUCTION IN NEAR EXISTING BUILDINGS

- .1 Building Exits: All exits, including stairways and exterior doors to the outside, serving the existing building shall be maintained.
- .2 Fire Department Access: Construction activities shall not obstruct the access roadways designated for fire department equipment.

1.9 PROJECT MEETINGS

- .1 Attend project meetings.
- .2 Representatives of Contractor, Subcontractor and suppliers attending meetings will be qualified and authorized to act on behalf of party each represents.
- .3 Consultant will distribute written notice of meetings, prepare agenda, record minutes and distribute copies of minutes.

1.10 HEALTH & SAFETY

- .1 The Owner is firmly committed to Corporate Health & Safety.
- .2 The Contractor shall have Corporate Health and Safety Policies and Procedures as required in the Occupational Health and Safety Act and Regulations for Construction Projects, R.S.O. 1980.
- .3 To provide a safe and healthy work environment the Contractor warrants and confirms:

- .1 that it has a written Health and Safety policy in place in accordance with the Occupational Health and Safety Act, R.S.O. 1990;
 - .2 that the appropriate instruction and training has been provided to the employees in accordance with the Occupational Health and Safety Act, R.S.O. 1990 and
 - .3 that the works shall be undertaken in strict accordance with all applicable provisions of the Occupational Health and Safety Act.
Note: In cases of discrepancy in document content, the Policy or Procedure providing the highest level of Health and Safety shall govern.
 - .4 The Bidder's documentation and commitment to Health & Safety will be a requirement of this contract.
- .4 Submit copies of incident and accident reports.

1.11 FILING OF NOTICE

- .1 File Notice of Project with Ontario Ministry of Labour prior to beginning of Work.

1.12 REGULATORY REQUIREMENTS

- .1 References and Codes
 - .1 Perform Work in accordance with the Ontario Building Code (OBC) including amendments up to tender closing date and other codes of provincial or local application provided that in case of conflict or discrepancy, more stringent requirements apply.
 - .2 Meet or exceed requirements of:
 - .1 Contract documents.
 - .2 Specified standards, codes and referenced documents.

1.13 INSPECTION

- .1 Allow Owner and Consultant access to Work. If part of Work is in preparation at locations other than Place of Work, allow access to such Work whenever it is in progress.
- .2 If Contractor covers or permits to be covered Work that has been designated for special tests, inspections or approvals before such is made, uncover such Work, have inspections or tests satisfactorily completed and make good such Work.
- .3 Consultant will order part of Work to be examined if Work is suspected to be not in accordance with Contract Documents. If, upon examination such work is found not in accordance with Contract Documents, correct such Work and pay cost of examination and correction. If such Work is found in accordance with Contract Documents, Owner shall pay cost of examination and replacement.

1.14 REJECTED WORK

- .1 Remove defective Work, whether result of poor workmanship, use of defective products or damage and whether incorporated in Work or not, which has been rejected by Consultant as failing to conform to Contract Documents. Replace or re-execute in accordance with Contract Documents.
- .2 Make good other Contractor's work damaged by such removals or replacements promptly.
- .3 If in opinion of Consultant it is not expedient to correct defective Work or Work not performed in accordance with Contract Documents, Owner will deduct from Contract

Price difference in value between Work performed and that called for by Contract Documents, amount of which will be determined by Consultant.

1.15 PROJECT CLEANLINESS

- .1 Maintain Work in tidy condition, free from accumulation of waste products and debris.
- .2 Remove waste materials from site at daily regularly scheduled times. Do not burn waste materials on site.
- .3 Make arrangements with and obtain permits from authorities having jurisdiction for disposal of waste and debris.
- .5 Provide on-site containers for collection of waste materials and debris.
- .6 Provide and use marked separate bins for recycling.
- .7 Dispose of waste materials and debris off site.
- .8 Protect existing materials and equipment from damage during construction. Provide polyethylene cover over any furniture and equipment remaining in work area in order to minimize damage from construction dirt and debris.
- .9 Clean interior areas prior to start of finishing work, and maintain areas free of dust and other contaminants during finishing operations.
- .10 Store volatile waste in covered metal containers, and remove from premises at end of each working day.
- .11 Provide adequate ventilation during use of volatile or noxious substances. Use of building ventilation systems is not permitted for this purpose.
- .12 Use only cleaning materials recommended by manufacturer of surface to be cleaned, and as recommended by cleaning material manufacturer.
- .13 Schedule cleaning operations so that resulting dust, debris and other contaminants will not fall on wet, newly painted surfaces nor contaminate building systems.

Part 2 Products

2.1 NOT USED

- .1 Not used.

Part 3 Execution

3.1 NOT USED

- .1 Not used.

END OF SECTION

Part 1

General

- .1 Include in Contract Price specified cash allowances.
- .2 Cash allowances, unless otherwise specified, cover net cost to Contractor of services, products, construction machinery and equipment, freight, handling, unloading, storage installation and other authorized expenses incurred in performing Work.
- .3 Contract Price, and not cash allowance, includes Contractor's overhead and profit in connection with such cash allowance.
- .4 Contract Price, and not cash allowance, includes HST payable in connection with such cash allowance.
- .5 Contract Price will be adjusted by written order to provide for excess or deficit to each cash allowance.
- .6 If overhead and profit to the Contract are determined by means not identified in the Contract Documents, edit the following paragraph to suit conditions accordingly.
- .7 Where costs under a cash allowance exceed amount of allowance, Contractor will be compensated for excess incurred and substantiated plus allowance for overhead and profit as set out in Contract Documents.
- .8 Include progress payments on accounts of work authorized under cash allowances in Consultant's monthly certificate for payment.
- .8 Authorization to Disburse Allowances: Expenditures from Allowances included in the contract must be authorized in writing by the Consultant, the Owner and the Contractor and issued as a Cash Allowance Disbursement Authorization (CADA).
- .9 Include the following cash allowances in the Stipulated Price.
 - .1 Cash Allowance: Ten Thousand Dollars (\$10,000.00) to cover the following items from which the Consultant shall direct payment for services, labour, and material.
 - .1 Provisional Cash Allowance
 - .2 Owner's Provisional Allowance
 - .2 Testing Allowance: For various Testing, Five Thousand Dollars (\$5,000.00).

PART 2 – PRODUCTS – Not Used

PART 3 – EXECUTION – Not used

End Of Section

Part 1 General

1.1 REFERENCES

- .1 Canadian Construction Documents Committee (CCDC)
 - .1 CCDC 23-2005, A Guide to Calling Bids and Awarding Contracts.

1.2 REQUIREMENTS

- .1 Referenced specification Sections stipulate pertinent requirements for products and methods to achieve Work stipulated under each Separate Price.
- .2 Co-ordinate affected related Work and modify surrounding Work to integrate Work under each Separate Price. Separate Prices will be considered when determining the lowest bidder.
- .3 In accordance with CCDC Document No. 23 - A Guide to Calling Bids and Awarding Contracts, low Bid will be determined on basis of lowest Bid in accordance with Contract Documents on which Project is to be actually constructed, including those Separate Prices for which prices have been invited and which are to be incorporated in Work.

1.3 AWARD/SELECTION OF SEPARATE PRICES

- .1 Indicate variation of Bid Price for Separate Prices described below and listed in Bid Form Appendix E. Note that this form requests a 'difference' in Bid. Price by adding to the Base Bid price.

1.4 SEPARATE PRICES

- .1 Separate Price No. 1: Asphalt replacement at Basketball Courts as shown on Drawing A101

Part 2 Products

2.1 NOT USED

- .1 Not Used.

Part 3 Execution

3.1 NOT USED

- .1 Not Used.

END OF SECTION

Part 1 General

1.1 SECTION INCLUDES

- .1 Contract modification procedures.

1.2 VARIATIONS

- .1 Once a Proposed Change has been issued by the Consultant, it shall be the responsibility of the Contractor to ensure that no work is carried out that may increase the cost of the variation contemplated until a decision on the acceptance or rejection of the Proposed Change is made, and a Change Order has been issued.
- .2 The Consultant will assess the cost of each change before issuing a Change Order. Assist the Consultant with this task by quoting all variations in a complete manner listing:
quantity of each material,
unit cost of each material,
man hours involved,
cost per hour,
Subcontractor quotations,
impact on Project schedule and completion, and
overhead and profit fees.
- .3 The Consultant may require further quotations in order to show a breakdown of costs.
- .4 The Owner and the Consultant will not be responsible for delays to the Work resulting from late, incomplete or inadequately broken down valuations submitted by the Contractor.
- .5 Minor variations may be made in the project from time to time as approved by the Consultant. Such alterations or adjustments shall not constitute a change in cost unless a Proposed Change is made at the time. No extra will be contemplated except where a clear indication is made that extra payment is claimed, in which case a Change Order will be issued by the Consultant. Unless this procedure is followed, no claims for additional amounts will be allowed.
- .6 Changes in the Work will be subject to the allowable mark-up as follows:
.1 The value of changes in the Work shall be determined by one of the following methods as agreed to by the Contractor and the Owner:
.1 estimate and acceptance in a lump sum, substantiated by an itemized Cost Breakdown satisfactory to the Owner with overhead and profit applied at the percentages listed below.
.2 The itemized "Cost Breakdown" shall include all net costs to the Contractor excluding his overhead and profit. "Overhead and Profit" shall be calculated at the rates listed below. "Overhead" shall include the following costs to the Contractor:
.1 The Contractor's head office and site office expenses, including stationery, postage and other office supplies.
.2 The salaries of superintendents, engineers, timekeepers, accountants, clerks, watchmen, and similar personnel employed directly on the Work. Wages on workers and foreman and the assessments thereon for Worker's Compensation, Unemployment Insurance, vacation with pay, and Canada Pension payments, etc., are part of the actual cost.
.3 Use of temporary offices, sheds, etc., including cost of telephone, light, power, water and heat used therein.
.4 Transportation and overnight room expenses for out of town labour, if local labour is not available.
.5 Insurance and bond premiums.
.6 Licenses and permits, except when these are special for a particular item of work.

- .7 Printing charges for Proposed Changes, Change Orders and Drawings for Contractor and Subcontractors use in the work. (Consultant will provide one copy of change notice documentation and in the event of re-issue of full size drawings will provide one copy of drawings.)
- .3 On work done by the General Contractor's own forces, a maximum of 5% overhead plus 5% profit shall be the percentage Fee applied to the net cost.
- .4 On work done by Subcontractors, the General Contractor shall charge a maximum of 5% as the percentage Fee applied to the net cost.
- .5 No mark-ups on credits, for overhead and profit, will be permitted.
- .6 Subcontractors - on work done by the Subcontractor's own forces, a maximum of 5% overhead plus 5% profit shall be the percentage Fee applied to the net cost

PART 2 – PRODUCTS – Not Used

PART 3 – EXECUTION – Not used

END OF SECTION

Part 1 General

1.1 REFERENCES

- .1 Owner/Contractor Agreement; CCDC2-2008, as Amended.

1.2 APPLICATIONS FOR PROGRESS PAYMENT

- .1 Make applications for payment on account monthly as Work progresses.
- .2 Date applications for payment last day of agreed monthly payment period and ensure amount claimed is for value, proportionate to amount of Contract, of Work performed and Products delivered to Place of Work at that date.
- .3 Submit to Consultant, at least 14 days before first application for payment. Schedule of values for parts of Work, aggregating total amount of Contract Price, to facilitate evaluation of applications for payment.

1.3 SCHEDULE OF VALUES

- .1 Provide schedule of values supported by evidence as Consultant may reasonably direct and when accepted by Consultant, be used as basis for applications for payment.
- .2 Include statement based on schedule of values with each application for payment.
- .3 Support claims for products delivered to Place of Work but not yet incorporated into Work by such evidence as Consultant may reasonably require to establish value and delivery of products.
- .4 Schedule of Values to include a value of One Thousand Dollars (\$1,000.00) for project close-out documents (as-builts and maintenance manuals). Payments for close-out documents will be released after documents are submitted and approved by the consultants.

1.4 PROGRESS PAYMENT

- .1 Consultant will issue to Owner, no later than 10 days after receipt of an application for payment, certificate for payment in amount applied for or in such other amount as Consultant determines to be due.

1.5 SUBSTANTIAL PERFORMANCE OF WORK

- .1 Apply for a review by Consultant to establish Substantial Performance of Work when Work is substantially performed if permitted by lien legislation applicable to Place of Work
- .2 No later than 10 days after receipt of list and application, Consultant will review Work to verify validity of application, and no later than 7 days after completing review, will notify Contractor if Work or designated portion of Work is substantially performed.
- .3 Consultant will state date of Substantial Performance of Work in certificate.
- .4 Immediately following issuance of certificate of Substantial Performance of Work, in consultation with Consultant, establish reasonable date for finishing Work.

1.6 PAYMENT OF HOLDBACK UPON SUBSTANTIAL PERFORMANCE OF WORK

- .1 After issuance of certificate of Substantial Performance of Work:
 - .1 Submit application for payment of holdback amount.
 - .2 Submit sworn statement that accounts for labour, subcontracts, products, construction machinery and equipment, and other indebtedness which may have been incurred in Substantial Performance of Work and for which Owner might in be held responsible have been paid in full, except for amounts properly retained as holdback or as identified amount in dispute.
- .2 After receipt of application for payment and sworn statement, Consultant will issue certificate for payment of holdback amount.

- .3 Amount authorized by certificate for payment of holdback amount is due and payable on day following expiration of holdback period stipulated in lien legislation applicable to Place of Work. Owner may retain out of holdback amount sums required by law to satisfy liens against Work.

1.7 FINAL PAYMENT

- .1 Submit application for final payment when Work is completed.
- .2 Consultant will, no later than 10 days after receipt of application for final payment, review Work to verify validity of application. Consultant will give notification that application is valid or give reasons why it is not valid, no later than 7 days after reviewing Work.
- .3 Consultant will issue final certificate for payment when application for final payment is found valid.

PART 2 – PRODUCTS – Not Used

PART 3 – EXECUTION – Not used

End Of Section

Part 1 General

1.1 ADMINISTRATIVE

- .1 Security and control of Project is the responsibility of the Contractor.
- .2 Contractor responsible as to which trade provides required materials or articles and work.
- .3 Contractor responsible for the coordination of all building components, materials and systems and the work of all subcontractors. The contractor will provide field drawings to coordinate the various parts of the work prior to commencement of work.

1.2 PRODUCT DELIVERY, STORAGE AND HANDLING

- .1 Schedule delivery of products, and provide delivery access and unloading areas.
- .2 Provide areas for storage of products and construction equipment to meet specified requirements, and to ensure a minimum of interference with progress of the Work and relocations.
- .3 All material, equipment and fixtures to be delivered, stored and handled as per manufacturer's written instructions.

1.3 JOB CONDITIONS

- .1 Ensure that conditions within the building are maintained. Ensure that protection of adjacent property and the Work is adequately provided for and maintained to meet specified requirements.

1.4 COORDINATION

- .1 Review Contract Documents and advise the Consultant of possible conflicts between parts of the Work before preparation of shop drawings, ordering of products or commencement of affected Work.
- .2 Coordinate all Work in each area and Work on which subsequent Work depends to facilitate mutual progress, and to prevent conflict between parts of the Work.
- .3 Ensure that each Section, before commencing its Work, knows requirements for subsequent Work and that each Section is assisted in the execution of its preparatory Work by Sections whose Work depends upon it.
- .4 Ensure that setting drawings, templates, and all other information necessary for the location and installation of materials, holes, sleeves, inserts, anchors, accessories, fastenings, connections, and access panels are provided by each Section whose Work requires cooperative location and installation by other Sections, and that such information is communicated to the applicable installer.

PART 2 – PRODUCTS – Not Used

PART 3 – EXECUTION – Not used

End Of Section

Part 1 General

1.1 ADMINISTRATIVE

- .1 Schedule project meetings throughout the progress of the work, every other week.
- .2 Provide physical space and make arrangements for meetings.
- .3 Attend meetings.
- .4 Representative of Contractor, Subcontractor and suppliers attending meetings will be qualified and authorized to act on behalf of party each represents.
- .5 Consultant will distribute written notice of meetings, prepare agenda, record minutes and distribute copies of minutes.

1.2 PRECONSTRUCTION MEETING

- .1 Within 15 days after award of Contract, request a meeting of parties in contract to discuss and resolve administrative procedures and responsibilities.
- .2 Client Representatives, Consultant, Contractor, Major Subcontractors and site supervisor shall be in attendance.
- .3 Establish time and location of meeting and notify parties concerned.
- .4 Consultant to provide agenda.
- .5 Contractor to have available prior to meeting, construction schedule, Schedule of Values and all contract security.

1.3 PROGRESS MEETINGS

- .1 During course of Work schedule and attend progress meetings.
- .2 Contractor, major Subcontractors involved in Work, Consultant and Owner are to be in attendance.
- .3 Contractor to have available prior to meeting, construction schedule and schedule of Values.

PART 2 – PRODUCTS – Not Used

PART 3 – EXECUTION – Not used

End Of Section

Part 1 General

1.1 DEFINITIONS

- .1 Activity: elements of Work performed during the course of Project. Activity has expected duration, and expected cost and expected resource requirements. Activities can be subdivided into tasks.
- .2 Bar Chart (GANTT Chart): graphic display of schedule-related information. In typical bar chart, activities or other Project elements are listed down left side of chart, dates are shown across top, and activity durations are shown as date-placed horizontal bars. Generally Bar Chart should be derived from commercially available computerized project management system.
- .3 Baseline: original approved plan (for project, work package, or activity), plus or minus approved scope changes.
- .4 Construction Work Week: Monday to Friday, inclusive, will provide five day work week and define schedule calendar working days as part of Bar (GANTT) Chart submission.
- .5 Duration: number of work periods (not including holidays or other nonworking periods) required to complete activity or other project element. Usually expressed as workdays or workweeks.
- .6 Master Plan: summary-level schedule that identifies major activities and key milestones.
- .7 Milestone: significant event in project, usually completion of major deliverable.
- .8 Project Schedule: planned dates for performing activities and the planned dates for meeting milestones. Dynamic, detailed record of tasks or activities that must be accomplished to satisfy Project objectives. Monitoring and control process involves using Project Schedule in executing and controlling activities and is used as basis for decision making throughout project life cycle.

1.2 REQUIREMENTS

- .1 Ensure Master Plan and Detail Schedules are practical and remain within specified Contract duration.
- .2 Plan to complete Work in accordance with prescribed milestones and time frame.
- .3 Limit activity durations to maximum of approximately 10 working days, to allow for progress reporting.
- .4 Ensure that it is understood that Award of Contract or time of beginning, rate of progress, and Substantial Performance as defined times of completion are of essence of this contract.

1.3 ACTION AND INFORMATION SUBMITTALS

- .1 Provide submittals in accordance with Section 01 33 00 - Submittal Procedures.
- .2 Submit Project Schedule to Consultant within 5 working days of receipt of acceptance of award of Contract.

1.4 PROJECT MILESTONES

- .1 Provide Project milestones from interim targets for Project Schedule. Include the following Milestones:
 - .1 Construction Start: June 28, 2019
 - .2 Substantial Performance: August 23, 2019

1.5 PROJECT SCHEDULE

- .1 Develop detail Project Schedule
- .2 Ensure detail Project Schedule includes a minimum milestone and activity types as follows:
 - .1 Award
 - .2 Shop Drawing Submission, Samples
 - .3 Permits
 - .4 Mobilizations
 - .5 Demolition
 - .6 New Asphalt
 - .7 Close-out Documentation Submission
 - .8 Substantial Performance

1.6 PROJECT SCHEDULE REPORTING

- .1 Update Project Schedule on bi-weekly basis reflecting activity changes and completions, as well as activities in progress.
- .2 Discuss Project Schedule at regular site meetings, identifying activities that are behind schedule and provide measures to regain slippage. Activities considered behind schedule are those with projected start or completion dates later than current approved dates shown on baseline schedule
- .3 Weather related delays with their remedial measures will be discussed and negotiated.

PART 2 – PRODUCTS – Not Used

PART 3 – EXECUTION – Not used

End Of Section

Part 1 General

1.1 ADMINISTRATIVE

- .1 Submit to Consultant submittals listed for review. Submit promptly and in orderly sequence to not cause delay in Work. Failure to submit in ample time is not considered sufficient reason for extension of Contract Time and no claim for extension by reason of such default will be allowed.
- .2 Do not proceed with Work affected by submittal until review is complete.
- .3 Present shop drawings, product data, samples and mock-ups in Imperial units.
- .4 Review submittals prior to submission to Consultant. This review represents that necessary requirements have been determined and verified, or will be, and that each submittal has been checked and co-ordinated with requirements of Work and Contract Documents. Submittals not stamped, signed, dated and identified as to specific project will be returned without being examined and considered rejected.
- .5 Notify Consultant, in writing at time of submission, identifying deviations from requirements of Contract Documents stating reasons for deviations.
- .6 Verify field measurements and affected adjacent Work are co-ordinated.
- .7 Contractor's responsibility for errors and omissions in submission is not relieved by Consultant's review of submittals.
- .8 Contractor's responsibility for deviations in submission from requirements of Contract Documents is not relieved by Consultant review.
- .9 Keep one reviewed copy of each submission on site.

1.2 SHOP DRAWINGS AND PRODUCT DATA

- .1 The term "shop drawings" means drawings, diagrams, illustrations, schedules, performance charts, brochures and other data which are to be provided by Contractor to illustrate details of a portion of Work.
- .2 Submit drawings stamped and signed by professional engineer registered or licensed in Province of Ontario Canada.
- .3 Indicate materials, methods of construction and attachment or anchorage, erection diagrams, connections, explanatory notes and other information necessary for completion of Work. Where articles or equipment attach or connect to other articles or equipment, indicate that such items have been co-ordinated, regardless of Section under which adjacent items will be supplied and installed. Indicate cross references to design drawings and specifications.
- .4 Allow 7 days for Consultant's review of each submission.
- .5 Adjustments made on shop drawings by Consultant are not intended to change Contract Price. If adjustments affect value of Work, state such in writing to Consultant prior to proceeding with Work.
- .6 Make changes in shop drawings as Consultant may require, consistent with Contract Documents. When resubmitting, notify Consultant in writing of revisions other than those requested.
- .7 Accompany submissions with transmittal letter, containing:
 - .1 Date.
 - .2 Project title and number.
 - .3 Contractor's name and address.
 - .4 Identification and quantity of each shop drawing, product data and sample.
 - .5 Other pertinent data.

- .8 Submissions include:
 - .1 Date and revision dates.
 - .2 Project title and number.
 - .3 Name and address of:
 - .1 Subcontractor.
 - .2 Supplier.
 - .3 Manufacturer.
 - .4 Contractor's stamp, signed by Contractor's authorized representative certifying approval of submissions, verification of field measurements and compliance with Contract Documents.
 - .5 Details of appropriate portions of Work as applicable:
 - .1 Fabrication.
 - .2 Layout, showing dimensions, including identified field dimensions, and clearances.
 - .3 Setting or erection details.
 - .4 Capacities.
 - .5 Performance characteristics.
 - .6 Standards.
 - .7 Operating weight.
 - .8 Wiring diagrams.
 - .9 Single line and schematic diagrams.
 - .10 Relationship to adjacent work.
- .9 After Consultant's review, distribute copies.
- .10 Submit 6 prints or 1 electronic copy of shop drawings for each requirement requested in specification Sections and as Consultant may reasonably request.
- .11 Submit 6 prints or 1 electronic copies of product data sheets or brochures for requirements requested in specification Sections and as requested by Consultant where shop drawings will not be prepared due to standardized manufacture of product.
- .12 Submit 6 copies or 1 electronic copy of test reports for requirements requested in specification Sections and as requested by Consultant.
 - .1 Report signed by authorized official of testing laboratory that material, product or system identical to material, product or system to be provided has been tested in accord with specified requirements.
 - .2 Testing must have been within 3 years of date of contract award for project.
- .13 Submit 6 copies or 1 electronic copy of certificates for requirements requested in specification Sections and as requested by Consultant.
 - .1 Statements printed on manufacturer's letterhead and signed by responsible officials of manufacturer of product, system or material attesting that product, system or material meets specification requirements.
 - .2 Certificates must be dated after award of project contract complete with project name.
- .14 Submit 6 copies or 1 electronic copy of manufacturer's instructions for requirements requested in specification Sections and as requested by Consultant.
 - .1 Pre-printed material describing installation of product, system or material, including special notices and Material Safety Data Sheets concerning impedances, hazards and safety precautions.
- .15 Submit 6 copies or 1 electronic copy of Manufacturer's Field Reports for requirements requested in specification Sections and as requested by Consultant.
- .16 Documentation of the testing and verification actions taken by manufacturer's representative to confirm compliance with manufacturer's standards or instructions.
- .17 Submit 1 Hard copy and 1 digital copy (PDF Format) of Operation and Maintenance Data for requirements requested in specification Sections and as requested by Consultant.
- .18 Delete information not applicable to project.
- .19 Supplement standard information to provide details applicable to project.

- .20 If upon review by Consultant, no errors or omissions are discovered or if only minor corrections are made, copies will be returned and fabrication and installation of Work may proceed. If shop drawings are rejected, noted copy will be returned and resubmission of corrected shop drawings, through same procedure indicated above, must be performed before fabrication and installation of Work may proceed.

1.3 SAMPLES

- .1 Submit for review samples in duplicate as requested in respective specification Sections. Label samples with origin and intended use.
- .2 Deliver samples prepaid to Consultant's business address.
- .3 Notify Consultant in writing, at time of submission of deviations in samples from requirements of Contract Documents.
- .4 Where colour, pattern or texture is criterion, submit full range of samples.
- .5 Make changes in samples which Consultant may require, consistent with Contract Documents.
- .6 Reviewed and accepted samples will become standard of workmanship and material against which installed Work will be verified.

PART 2 – PRODUCTS – Not Used

PART 3 – EXECUTION – Not used

End Of Section

Part 1

General

1.1 SECTION INCLUDES

- .1 Health and safety considerations required to ensure that the Contractor shows due diligence towards health and safety on construction sites.

1.2 REFERENCES

- .1 Canada Labour Code, Part 2, Canada Occupational Safety and Health Regulations
- .2 Health Canada/Workplace Hazardous Materials Information System (WHMIS)
 - .1 Material Safety Data Sheets (MSDS).
 - .2 Occupational Health and Safety Act, S.N.S. 1996.
- .3 Province of Ontario
 - .1 Occupational Health and Safety Act, R.S.O. 1990 Updated 2005.

1.3 HEALTH & SAFETY

- .1 The Owner is firmly committed to Corporate Health & Safety.
- .2 The Contractor shall have Corporate Health and Safety Policies and Procedures as required in the Occupational Health and Safety Act and Regulations for Construction Projects, R.S.O. 1980.
- .3 To provide a safe and healthy work environment the Contractor warrants and confirms:
 - .1 that it has a written Health and Safety policy in place in accordance with the Occupational Health and Safety Act, R.S.O. 1990;
 - .2 that the appropriate instruction and training has been provided to the employees in accordance with the Occupational Health and Safety Act, R.S.O. 1990 and
 - .3 that the works shall be undertaken in strict accordance with all applicable provisions of the Occupational Health and Safety Act.
Note: In cases of discrepancy in document content, the Policy or Procedure providing the highest level of Health and Safety shall govern.
 - .4 The Bidder's documentation and commitment to Health & Safety will be a requirement of this contract.
- .4 Submit copies of incident and accident reports.

1.4 FILING OF NOTICE

- .1 File Notice of Project with Ontario Ministry of Labour prior to beginning of Work.

1.5 REGULATORY REQUIREMENTS

- .1 Do Work in accordance with Section 01 41 00 - Regulatory Requirements.

1.6 RESPONSIBILITY

- .1 Be responsible for health and safety of persons on site, safety of property on site and for protection of persons adjacent to site and environment to extent that they may be affected by conduct of Work.
- .2 Comply with and enforce compliance by employees with safety requirements of Contract Documents, applicable federal, provincial, territorial and local statutes, regulations, and ordinances.

1.7 COMPLIANCE REQUIREMENTS

- .1 Comply with Ontario Health and Safety Act, R.S.O.
- .2 Comply with Canada Labour Code, Canada Occupational Safety and Health Regulations.

- 1.8 UNFORSEEN HAZARDS**
.1 When unforeseen or peculiar safety-related factor, hazard, or condition occur during performance of Work, follow procedures in place for Employee's Right to Refuse Work in accordance with Acts and Regulations of Province of Ontario having jurisdiction and advise Consultant verbally and in writing.
- 1.9 POSTING OF DOCUMENTS**
.1 Ensure applicable items, articles, notices and orders are posted in conspicuous location on site in accordance with Acts and Regulations of Province of Ontario having jurisdiction.
- 1.10 CORRECTION OF NON-COMPLIANCE**
.1 Immediately address health and safety non-compliance issues identified by authority having jurisdiction or by Consultant.
.2
- 1.11 BLASTING**
.1 Blasting or other use of explosives is not permitted.
- 1.12 POWDER ACTUATED DEVICES**
.1 Powder actuated devices are not permitted.
- 1.13 WORK STOPPAGE**
.1 Give precedence to safety and health of public and site personnel and protection of environment over cost and schedule considerations for Work.

PART 2 – PRODUCTS – Not Used

PART 3 – EXECUTION – Not used

End Of Section

Part 1 General

1.1 FIRES

- .1 Fires and burning of rubbish on site not permitted.

1.2 DRAINAGE

- .1 Provide temporary drainage and pumping required to keep excavations and site free from water.
- .2 Ensure pumped water into waterways, sewer or drainage systems is free of suspended materials.
- .3 Control disposal or runoff of water containing suspended materials or other harmful substances in accordance with local authority requirements.

1.3 SITE CLEARING AND PLANT PROTECTION

- .1 Protect trees and plants on site and adjacent properties as indicated.
- .2 Protect roots of designated trees to dripline during excavation and site grading to prevent disturbance or damage.
- .3 Avoid unnecessary traffic, dumping and storage of materials over root zones.

1.4 POLLUTION CONTROL

- .1 Maintain temporary erosion and pollution control features installed under this Contract.
- .2 Control emissions from equipment and plant in accordance with local authorities' emission requirements.
- .3 Cover or wet down dry materials and rubbish to prevent blowing dust and debris. Provide dust control for temporary roads.

1.5 NOTIFICATION

- .1 Consultant will notify Contractor in writing of observed noncompliance with Federal, Provincial or Municipal environmental laws or regulations, permits, and other elements of Contractor's Environmental Protection plan.
- .2 Contractor: after receipt of such notice, inform Consultant of proposed corrective action and take such action for approval by Consultant.
 - .1 Take action only after receipt of written approval by Consultant.
- .3 Consultant will issue stop order of work until satisfactory corrective action has been taken.
- .4 No time extensions granted or equitable adjustments allowed to Contractor for such suspensions.

Part 2 Products - Not Used

Part 3 Execution

3.1 CLEANING

- .1 Ensure public waterways, storm and sanitary sewers remain free of waste and volatile materials disposal.
- .2 Progress Cleaning: clean in accordance with Section 01 74 11 - Cleaning.
 - .1 Leave Work area clean at end of each day.
- .3 Final Cleaning: upon completion remove surplus materials, rubbish, tools and equipment in accordance with Section 01 74 11 - Cleaning.
- .4 Waste Management: separate waste materials for reuse or recycling.
 - .1 Remove recycling containers and bins from site and dispose of materials at appropriate facility

End Of Section

Part 1 General

1.1 REFERENCES AND CODES

- .1 Perform Work in accordance with the Ontario Building Code (OBC) including amendments up to tender closing date and other codes of provincial or local application provided that in case of conflict or discrepancy, more stringent requirements apply.
- .2 Meet or exceed requirements of:
 - .1 Contract documents.
 - .2 Specified standards, codes and referenced documents.

1.2 HAZARDOUS MATERIAL DISCOVERY

- .1 Asbestos: demolition of spray or trowel-applied asbestos is hazardous to health. Stop work immediately when material resembling spray or trowel-applied asbestos is encountered during demolition work. Notify Consultant.
- .2 Mould: stop work immediately when material resembling mould is encountered during demolition work. Notify Consultant.

PART 2 – PRODUCTS – Not Used

PART 3 – EXECUTION – Not used

End Of Section

Part 1 General

1.1 INSPECTION

- .1 Allow Owner and Consultant access to Work.
- .2 If Contractor covers or permits to be covered Work that has been designated for special tests, inspections or approvals before such is made, uncover such Work, have inspections or tests satisfactorily completed and make good such Work.
- .3 Give timely notice requesting inspection if Work is designated for special tests, inspections or approvals by consultants or law of Place of Work.
- .4 Consultant will order part of Work to be examined if Work is suspected to be not in accordance with Contract Documents. If, upon examination such work is found not in accordance with Contract Documents, correct such Work and pay cost of examination and correction. If such Work is found in accordance with Contract Documents, Owner shall pay cost of examination and replacement.

1.2 REJECTED WORK

- .1 Remove defective Work, whether result of poor workmanship, use of defective products or damage and whether incorporated in Work or not, which has been rejected by Consultant as failing to conform to Contract Documents. Replace or re-execute in accordance with Contract Documents.
- .2 If in opinion of Consultant it is not expedient to correct defective Work or Work not performed in accordance with Contract Documents, Owner will deduct from Contract Price difference in value between Work performed and that called for by Contract Documents, amount of which will be determined by Consultant.

1.3 TESTING & REPORTS

- .1 Submit electronic copies of inspection and testing reports to Consultant.
- .2 Furnish test results and mix designs as requested.

1.4 MOCK-UPS

- .1 Prepare mock-ups for Work specifically requested in specifications. Include for Work of Sections required to provide mock-ups.
- .2 Prepare mock-ups for Consultants review with reasonable promptness and in orderly sequence, to not cause delays in Work.
- .3 Failure to prepare mock-ups in ample time is not considered sufficient reason for extension of Contract time and no claim for extension by reason of such default will be considered.
- .4 Mock-ups may remain as part of the work.

PART 2 – PRODUCTS – Not Used

PART 3 – EXECUTION – Not used

End Of Section

Part 1 General

1.1 INSTALLATION AND REMOVAL

- .1 Provide temporary utilities controls in order to execute work expeditiously.
- .2 Remove from site all such work after use.

1.2 DEWATERING

- .1 Provide temporary drainage and pumping facilities to keep excavations and site free from standing water.

1.3 WATER SUPPLY

- .1 Arrange, provide and pay for continuous supply of potable water for construction use.

1.4 TEMPORARY COMMUNICATION FACILITIES

- .1 Provide and pay for telephone, data and all necessary communication devices for own use.

1.5 FIRE PROTECTION

- .1 Burning rubbish and construction waste materials is not permitted on site.

PART 2 – PRODUCTS – Not Used

PART 3 – EXECUTION – Not used

End Of Section

Part 1 General

1.1 REFERENCES

- .1 Canadian Standards Association (CSA International)
 - .1 CAN/CSA-S269.2-M1987(R2003), Access Scaffolding for Construction Purposes.
 - .2 CAN/CSA-Z321-96(R2006), Signs and Symbols for the Occupational Environment.

1.2 INSTALLATION AND REMOVAL

- .1 Provide construction facilities in order to execute work expeditiously.
- .2 Remove from site all such work after use.

1.3 SCAFFOLDING

- .1 Scaffolding in accordance with CAN/CSA-S269.2.
- .2 Provide and maintain scaffolding, ramps, ladders, swing staging, platforms.

1.4 SITE STORAGE/LOADING

- .1 Confine work and operations of employees by Contract Documents. Do not unreasonably encumber premises with products.
- .2 Do not load or permit to load any part of Work with weight or force that will endanger Work.

1.5 CONSTRUCTION PARKING

- .1 Parking will be permitted on site in designated areas only.
- .2 Provide and maintain adequate access to project site.

1.6 EQUIPMENT, TOOL AND MATERIALS STORAGE

- .1 Provide and maintain, in clean and orderly condition, lockable weatherproof sheds for storage of tools, equipment and materials.
- .2 Locate materials not required to be stored in weatherproof sheds on site in manner to cause least interference with work activities.

1.7 SANITARY FACILITIES

- .1 Provide sanitary facilities for work force in accordance with governing regulations and ordinances.
- .2 Post notices and take precautions as required by local health authorities. Keep area and premises in sanitary condition.

1.8 CLEAN-UP

- .1 Remove construction debris, waste materials, packaging material from work site daily.
- .2 Clean dirt or mud tracked onto paved or surfaced roadways.

PART 2 – PRODUCTS – Not Used

PART 3 – EXECUTION – Not used

End Of Section

- Part 1** **General**
- 1.1** **INSTALLATION AND REMOVAL**
- .1 Provide temporary controls in order to execute Work expeditiously.
 - .2 Remove from site all such work after use.
- 1.2** **SITE FENCING | PROTECTION**
- .1 Erect temporary site enclosure using new 6'-0" (1.8 m) high portable construction fence. Provide minimum one lockable truck gate. Maintain fence in good repair.
 - .2 Provide barriers around trees and plants designated to remain. Protect from damage by equipment and construction procedures.
- 1.3** **GUARD RAILS AND BARRICADES**
- .1 Provide secure, rigid guard rails and barricades around deep excavations, open shafts, open stair wells, open edges of floors and roofs.
 - .2 Provide as required by governing authorities.
- 1.4** **ACCESS TO SITE**
- .1 Provide and maintain access roads and sidewalk crossings, as may be required for access to Work.
- 1.5** **FIRE ROUTES**
- .1 Maintain access to property including overhead clearances for use by emergency response vehicles.
- 1.6** **PROTECTION FOR OFF-SITE AND PUBLIC PROPERTY**
- .1 Protect surrounding private and public property from damage during performance of Work.
 - .2 Be responsible for damage incurred.
 - .3 **DO NOT** park or drive on the church parking lot adjacent to the school yard.
- 1.7** **PROTECTION OF BUILDING FINISHES**
- .1 Provide protection for finished areas of building and equipment during performance of Work.
 - .2 Provide necessary screens, covers, and hoardings.
 - .3 Be responsible for damage incurred due to lack of or improper protection.

PART 2 – PRODUCTS – Not Used

PART 3 – EXECUTION – Not used

End Of Section

Part 1 General

1.1 REFERENCES

- .1 Within text of each specifications section, reference may be made to reference standards.
- .2 Conform to these reference standards, in whole or in part as specifically requested in specifications.
- .3 If there is question as to whether products or systems are in conformance with applicable standards, Consultant reserves right to have such products or systems tested to prove or disprove conformance.
- .4 Cost for such testing will be borne by Owner in event of conformance with Contract Documents or by Contractor in event of non-conformance.

1.2 QUALITY

- .1 Products, materials, equipment and articles incorporated in Work shall be new, not damaged or defective, and of best quality for purpose intended. If requested, furnish evidence as to type, source and quality of products provided.
- .2 Procurement policy is to acquire, in cost effective manner, items containing highest percentage of recycled and recovered materials practicable consistent with maintaining satisfactory levels of competition. Make reasonable efforts to use recycled and recovered materials and in otherwise utilizing recycled and recovered materials in execution of work.
- .3 Defective products, whenever identified prior to completion of Work, will be rejected, regardless of previous inspections. Inspection does not relieve responsibility, but is precaution against oversight or error. Remove and replace defective products at own expense and be responsible for delays and expenses caused by rejection.
- .4 Should disputes arise as to quality or fitness of products, decision rests strictly with Consultant based upon requirements of Contract Documents.
- .5 Unless otherwise indicated in specifications, maintain uniformity of manufacture for any particular or like item throughout building.
- .6 Permanent labels, trademarks and nameplates on products are not acceptable in prominent locations, except where required for operating instructions, or when located in mechanical or electrical rooms.

1.3 AVAILABILITY

- .1 Immediately upon signing Contract, review product delivery requirements and anticipate foreseeable supply delays for items. If delays in supply of products are foreseeable, notify Consultant of such, in order that substitutions or other remedial action may be authorized in ample time to prevent delay in performance of Work.
- .2 In event of failure to notify Consultant at commencement of Work and should it subsequently appear that Work may be delayed for such reason, Consultant reserves right to substitute more readily available products of similar character, at no increase in Contract Price or Contract Time.

1.4 STORAGE, HANDLING AND PROTECTION

- .1 Handle and store products in manner to prevent damage, adulteration, deterioration and soiling and in accordance with manufacturer's instructions when applicable.
- .2 Store packaged or bundled products in original and undamaged condition with manufacturer's seal and labels intact. Do not remove from packaging or bundling until required in Work.
- .3 Store products subject to damage from weather in weatherproof enclosures.
- .4 Store and mix paints in heated and ventilated room. Remove oily rags and other combustible debris from site daily. Take every precaution necessary to prevent spontaneous combustion.
- .5 Remove and replace damaged products at own expense and to satisfaction of Consultant.

- .6 Touch-up damaged factory finished surfaces to Consultant's satisfaction. Use touch-up materials to match original. Do not paint over name plates.
- 1.5 TRANSPORTATION**
- .1 Pay costs of transportation of products required in performance of Work.
- 1.6 MANUFACTURER'S INSTRUCTIONS**
- .1 Unless otherwise indicated in specifications, install or erect products in accordance with manufacturer's instructions. Do not rely on labels or enclosures provided with products. Obtain written instructions directly from manufacturers.
- .2 Notify Consultant in writing, of conflicts between specifications and manufacturer's instructions, so that Consultant will establish course of action.
- .3 Improper installation or erection of products, due to failure in complying with these requirements, authorizes Consultant to require removal and re-installation at no increase in Contract Price or Contract Time.
- 1.7 QUALITY OF WORK**
- .1 Ensure Quality of Work is of highest standard, executed by workers experienced and skilled in respective duties for which they are employed. Immediately notify Consultant if required Work is such as to make it impractical to produce required results.
- .2 Do not employ anyone unskilled in their required duties. Consultant reserves right to require dismissal from site, workers deemed incompetent or careless.
- .3 Decisions as to standard or fitness of Quality of Work in cases of dispute rest solely with Consultant, whose decision is final.
- 1.8 CO-ORDINATION**
- .1 Ensure co-operation of workers in laying out Work. Maintain efficient and continuous supervision.
- .2 Be responsible for coordination and placement of openings, sleeves and accessories.
- 1.9 CONCEALMENT**
- .1 In finished areas conceal pipes, ducts and wiring in floors, walls and ceilings, except where indicated otherwise.
- .2 Before installation inform Consultant if there is interference. Install as directed by Consultant.
- 1.10 REMEDIAL WORK**
- .1 Perform remedial work required to repair or replace parts or portions of Work identified as defective or unacceptable. Co-ordinate adjacent affected Work as required.
- .2 Perform remedial work by specialists familiar with materials affected. Perform in a manner to neither damage nor put at risk any portion of Work.
- 1.11 LOCATION OF FIXTURES**
- .1 Consider location of fixtures, outlets, and mechanical and electrical items indicated as approximate.
- .2 Inform Consultant of conflicting installation. Install as directed.
- 1.12 FASTENINGS**
- .1 Provide metal fastenings and accessories in same texture, colour and finish as adjacent materials, unless indicated otherwise.
- .2 Prevent electrolytic action between dissimilar metals and materials.
- .3 Use non-corrosive hot dip galvanized steel fasteners and anchors for securing exterior work, unless stainless steel or other material is specifically requested in affected specification Section.

- .4 Space anchors within individual load limit or shear capacity and ensure they provide positive permanent anchorage. Wood, or any other organic material plugs are not acceptable.
- .5 Keep exposed fastenings to a minimum, space evenly and install neatly.
- .6 Fastenings which cause spalling or cracking of material to which anchorage is made are not acceptable.

1.13 FASTENINGS - EQUIPMENT

- .1 Use fastenings of standard commercial sizes and patterns with material and finish suitable for service.
- .2 Use heavy hexagon heads, semi-finished unless otherwise specified. Use No. 304 stainless steel for exterior areas.
- .3 Bolts may not project more than one diameter beyond nuts.
- .4 Use plain type washers on equipment, sheet metal and soft gasket lock type washers where vibrations occur. Use resilient washers with stainless steel.

1.14 PROTECTION OF WORK IN PROGRESS

- .1 Prevent overloading of parts of building. Do not cut, drill or sleeve load bearing structural member, unless specifically indicated without written approval of Consultant.

1.15 EXISTING UTILITIES

- .1 When breaking into or connecting to existing services or utilities, execute Work at times directed by local governing authorities, with minimum of disturbance to Work.
- .2 Protect, relocate or maintain existing active services. When services are encountered, cap off in manner approved by authority having jurisdiction. Record location of capped service.

PART 2 – PRODUCTS – Not Used

PART 3 – EXECUTION – Not used

End Of Section

Part 1 General

1.1 SURVEY REFERENCE POINTS

- .1 Existing base horizontal and vertical control points are designated on drawings.
- .2 Locate, confirm and protect control points prior to starting site work. Preserve permanent reference points during construction.
- .3 Report to consultant when reference point is lost or destroyed, or requires relocation because of necessary changes in grades or locations.
- .4 Require surveyor to replace control points in accordance with original survey control.

1.2 SURVEY REQUIREMENTS

- .1 Establish permanent bench marks on site, referenced to established bench marks by survey control points. Record locations, with horizontal and vertical data in Project Record Documents.
- .2 Establish lines and levels, locate and lay out, by instrumentation.
- .3 Stake for grading, and fill placement.
- .4 Establish pipe invert elevations.
- .5 Stake batter boards
- .6 Establish foundations, column locations and floor elevations.
- .7 Establish lines and levels for mechanical and electrical work.

1.3 EXISTING SERVICES

- .1 Before commencing work, establish location and extent of service lines in area of Work.
- .2 Remove abandoned service lines within 6 feet of structures. Cap or otherwise seal lines at cut-off points.

1.4 LOCATION OF EQUIPMENT AND FIXTURES

- .1 Location of equipment, fixtures and outlets indicated or specified are to be considered as approximate.
- .2 Locate equipment, fixtures and distribution systems to provide minimum interference and maximum usable space and in accordance with manufacturer's recommendations for safety, access and maintenance.
- .3 Submit field drawings to indicate relative position of various services and equipment.

1.5 RECORDS

- .1 Maintain a complete, accurate log of control and survey work as it progresses.
- .2 Record locations of maintained, re-routed and abandoned service lines.

1.6 SUBSURFACE CONDITIONS

- .1 Promptly notify Consultant in writing if subsurface conditions at Place of Work differ materially from those indicated in Geotechnical Report
After prompt investigation, should Consultant determine that conditions do differ materially, instructions will be issued for changes in Work accordingly.

PART 2 – PRODUCTS – Not Used

PART 3 – EXECUTION – Not used

End of Section

Part 1 General

1.1 SUBMITTALS

- .1 Submittals: in accordance with Section 01 33 00 - Submittal Procedures.
- .2 Submit written request in advance of cutting or alteration which affects:
 - .1 Structural integrity of elements of project.
 - .2 Integrity of weather-exposed or moisture-resistant elements.
 - .3 Efficiency, maintenance, or safety of operational elements.
 - .4 Visual qualities of sight-exposed elements.
 - .5 Work of Owner or separate contractor.
- .3 Include in request:
 - .1 Identification of project.
 - .2 Location and description of affected Work.
 - .3 Statement on necessity for cutting or alteration.
 - .4 Description of proposed Work, and products to be used.
 - .5 Alternatives to cutting and patching.
 - .6 Effect on Work of Owner or separate contractor.
 - .7 Written permission of affected separate contractor.
 - .8 Date and time work will be executed.

1.2 MATERIALS

- .1 Required for original installation.
- .2 Change in Materials: Submit request for substitution in accordance with Section 01 33 00 - Submittal Procedures.

1.3 PREPARATION

- .1 Inspect existing conditions, including elements subject to damage or movement during cutting and patching.
- .2 After uncovering, inspect conditions affecting performance of Work.
- .3 Beginning of cutting or patching means acceptance of existing conditions.
- .4 Provide supports to assure structural integrity of surroundings; provide devices and methods to protect other portions of project from damage.
- .5 Provide protection from elements for areas which are to be exposed by uncovering work; maintain excavations free of water.

1.4 EXECUTION

- .1 Execute cutting, fitting, and patching to complete Work.
- .2 Fit several parts together, to integrate with other Work.
- .3 Uncover Work to install ill-timed Work.
- .4 Remove and replace defective and non-conforming Work.
- .5 Provide openings in non-structural elements of Work for penetrations of mechanical and electrical Work.
- .6 Execute Work by methods to avoid damage to other Work, and which will provide proper surfaces to receive patching and finishing.
- .7 Employ original installer to perform cutting and patching for weather-exposed and moisture-resistant elements, and sight-exposed surfaces.
- .8 Cut rigid materials using masonry saw or core drill. Pneumatic or impact tools not allowed on masonry work without prior approval.
- .9 Restore work with new products in accordance with requirements of Contract Documents.
- .10 Fit Work airtight to pipes, sleeves, ducts, conduit, and other penetrations through surfaces.
- .11 At penetration of fire rated wall, ceiling, or floor construction, completely seal voids with firestopping material, full thickness of the construction element.

- .12 Refinish surfaces to match adjacent finishes: Refinish continuous surfaces to nearest intersection. Refinish assemblies by refinishing entire unit.
- .13 Conceal pipes, ducts and wiring in floor, wall and ceiling construction of finished areas except where indicated otherwise.

PART 2 – PRODUCTS – Not Used

PART 3 – EXECUTION – Not used

End Of Section

Part 1 General

1.1 PROJECT CLEANLINESS

- .1 Maintain Work in tidy condition, free from accumulation of waste products and debris.
- .2 Remove waste materials from site at regularly scheduled times. Do not burn waste materials on site.
- .3 Clear snow and ice from access to building, remove from site.
- .4 Make arrangements with and obtain permits from authorities having jurisdiction for disposal of waste and debris.
- .5 Provide on-site containers for collection of waste materials and debris.
- .6 Provide and use marked separate bins for recycling.
- .7 Dispose of waste materials and debris off site.
- .8 Store volatile waste in covered metal containers, and remove from premises at end of each working day.
- .9 Use only cleaning materials recommended by manufacturer of surface to be cleaned, and as recommended by cleaning material manufacturer.
- .10 Schedule cleaning operations so that resulting dust, debris and other contaminants will not fall on wet, newly painted surfaces nor contaminate building systems.

1.2 FINAL CLEANING

- .1 Refer to CCDC 2, GC 3.14.
- .2 When Work is Substantially Performed remove surplus products, tools, construction machinery and equipment not required for performance of remaining Work.
- .3 Remove waste products and debris other than that caused by others, and leave Work clean and suitable for occupancy.
- .4 Prior to final review remove surplus products, tools, construction machinery and equipment.
- .5 Remove waste materials from site at regularly scheduled times. Do not burn waste materials on site.
- .6 Make arrangements with and obtain permits from authorities having jurisdiction for disposal of waste and debris.
- .7 Remove stains, spots, marks and dirt from decorative work, electrical and mechanical fixtures, furniture fitments, walls.
- .8 Clean lighting reflectors, lenses, and other lighting surfaces.
- .9 Inspect finishes, fitments and equipment and ensure specified workmanship and operation.
- .10 Broom clean and wash exterior walks, steps and surfaces; rake clean other surfaces of grounds.
- .11 Remove dirt and other disfiguration from exterior surfaces.
- .12 Sweep and wash clean paved areas.
- .13 Clean equipment and fixtures to sanitary condition; clean or replace filters of mechanical equipment.
- .14 Remove snow and ice from access to building.

1.3 WASTE MANAGEMENT AND DISPOSAL

- .1 Separate waste materials for reuse or recycling.

PART 2 – PRODUCTS – Not Used

PART 3 – EXECUTION – Not used

End Of Section

Part 1 General

1.1 ADMINISTRATIVE PROCEDURES

- .1 Acceptance of Work Procedures:
 - .1 Contractor's Inspection: conduct inspection of Work , identify deficiencies and defects, and repair as required to conform to Contract documents.
 - .2 Notify Consultant in writing of satisfactory completion of Contractors inspection and submit verification that corrections have been made.
 - .3 Request Consultants inspections
 - .4 Consultants and Contactor to inspect Work and identify defects and deficiencies. Contractor to correct Work as directed.
- .2 Completion Tasks: submit written certificates and tasks have been preformed as follows:
 - .1 Work completed and inspected in compliance with Contract Documents.
 - .2 Defects / deficiencies have been corrected and completed
 - .3 Equipment and systems: Tested m balanced and fully operation as per Mechanical and electrical specifications.
 - .4 Operations of systems demonstrated to Owner's personnel.

1.2 CLOSEOUT PROCEDURES

- .1 The Consultant will not commence deficiency review until the General Contractor's own itemized deficiencies have been completed. The Consultant will make one inspection for deficiencies review and one final review at competition of all items. Each additional Site review will be made at a cost of \$1,200.00 per visit to be paid by the General Contractor.
- .2 Contractor to accompany Consultant on deficiency inspection.
- .3 Contractor to correct items of work listed on deficiency list in a efficient manner to allow owner areas to be turn over to Owner in a timely manner.
- .4 Notify in writing to Consultant when all corrective work is completed.

1.3 ACTION AND INFORMATIONAL SUBMITTALS

- .1 Two weeks prior to Substantial Performance of the Work, submit to the Consultant one (1) hard copy and one (1) digital copy of final operating and maintenance manuals in English, and hard copy of Record Drawings.
- .2 Provide spare parts, maintenance materials and special tools of same quality and manufacture as products provided in Work.

1.4 FORMAT

- .1 Organize data as instructional manual.
- .2 Binders: vinyl, hard covered, 3 'D' ring, loose leaf, to suit 8 ½' x 11" size paper, with spine and face pockets.
- .3 Cover: identify each binder with type or printed title 'Project Record Documents'; list title of project and identify subject matter of contents.
- .4 Arrange content by systems, under Section numbers and sequence of Table of Contents.
- .5 Provide tabbed fly leaf for each separate product and system, with typed description of product and major component parts of equipment.
- .6 Text: manufacturer's printed data, or typewritten data.
- .7 Drawings: provide with reinforced punched binder tab, bind in with text; fold larger drawings to size of text pages.

1.5 CONTENTS - PROJECT RECORD DOCUMENTS

- .1 Table of Contents for Each Volume: provide title of project;
 - .1 Date of submission; names.
 - .2 Addresses, and telephone numbers of Consultant and Contractor with name of responsible parties.

- .3 Schedule of products and systems, indexed to content of volume.
- .2 For each product or system:
 - .1 List names, addresses and telephone numbers of subcontractors and suppliers, including local source of supplies and replacement parts.
- .3 Product Data: mark each sheet to identify specific products and component parts, and data applicable to installation; delete inapplicable information.
- .4 Drawings: supplement product data to illustrate relations of component parts of equipment and systems, to show control and flow diagrams.
- .5 Typewritten Text: as required to supplement product data.
 - .1 Provide logical sequence of instructions for each procedure, incorporating manufacturer's instructions.
- .6 As Built Drawings: digital copies will be prepared by the Consultant.

1.6 **AS -BUILT DOCUMENTS AND SAMPLES**

- .1 Maintain, at site one record copy of:
 - .1 Contract Drawings.
 - .2 Specifications.
 - .3 Addenda.
 - .4 Change Orders and other modifications to Contract.
 - .5 Reviewed shop drawings, product data, and samples.
 - .6 Field test records.
 - .7 Inspection certificates.
 - .8 Manufacturer's certificates.
- .2 Store record documents and samples in field office apart from documents used for construction.
- .3 Maintain record documents in clean, dry and legible condition. Do not use record documents for construction purposes.
- .4 Keep record documents and samples available for inspection by Consultant.

1.7 **RECORDING INFORMATION ON PROJECT RECORD DOCUMENTS**

- .1 Record information on set of opaque drawings.
- .2 Use felt tip or ball point pens to record information, maintaining separate colours for each major system.
- .3 Record information concurrently with construction progress. Do not conceal Work until required information is recorded.
- .4 Contract Drawings and shop drawings: mark each item to record actual construction, including:
 - .1 Field changes of dimension and detail.
 - .2 Changes made by change orders.
 - .3 Details not on original Contract Drawings.
 - .4 References to related shop drawings and modifications.
- .5 Other Documents: maintain manufacturer's certifications, inspection certifications, field test records, required by individual specifications sections.
- .6 Provide digital photos, if requested, for site records.
- .7 Prior to Substantial Performance deliver Record Documents to Consultant for preparation of digital As Built Drawings. Consultant will transfer notations from opaque drawings to digital format.

1.8 **MATERIALS AND FINISHES**

- .1 Building products, applied materials, and finishes: include product data, with catalogue number, size, composition, and colour and texture designations.
- .2 Instructions for cleaning agents and methods, precautions against detrimental agents and methods, and recommended schedule for cleaning and maintenance.

- .3 Moisture-protection and weather-exposed products: include manufacturer's recommendations for cleaning agents and methods, precautions against detrimental agents and methods, and recommended schedule for cleaning and maintenance.
- .4 Additional requirements: as specified in individual specifications sections.

1.9 MAINTENANCE MATERIALS

- .1 Spare Parts, Extra Stock Materials and Special Tools:
 - .1 Provide, in quantities specified in individual specification sections.
 - .2 Provide items of same manufacture and quality as items in Work.
 - .3 Deliver to site; place and store.
 - .4 Receive and catalogue items.
 - .1 Include inventory listings in Maintenance Manual.
 - .5 Obtain receipt for delivered products and submit prior to final payment.

1.10 DELIVERY, STORAGE AND HANDLING

- .1 Store spare parts, maintenance materials, and special tools in manner to prevent damage or deterioration.
- .2 Store in original and undamaged condition with manufacturer's seal and labels intact.
- .3 Store components subject to damage from weather in weatherproof enclosures.
- .4 Store paints and freezable materials in a heated and ventilated room.

1.11 WARRANTIES AND BONDS

- .1 Assemble warranty and bond information in binder, submit upon acceptance of work and organize binder as follows:
 - .1 Separate each warranty or bond with index tab sheets keyed to Table of Contents listing.
 - .2 List subcontractor, supplier, and manufacturer, with name, address, and telephone number of responsible principal.
 - .3 Obtain warranties and bonds, executed in duplicate by subcontractors, suppliers, and manufacturers, within ten days after completion of applicable item of work.
 - .4 Verify that documents are in proper form, contain full information, and are notarized.
 - .5 Co-execute submittals when required.
 - .6 Retain warranties and bonds until time specified for submittal.
- .2 Leave date of beginning of time of warranty until Date of Substantial Performance is determined.
- .3 Respond in timely manner to oral or written notification of required construction warranty repair work.

PART 2 – PRODUCTS – Not Used

PART 3 – EXECUTION – Not used

End Of Section

Part 1 General

1.1 REFERENCES

- .1 Canadian Standards Association (CSA International)
 - .1 CSA S350-(R2003), Code of Practice for Safety in Demolition of Structures.

1.2 SITE CONDITIONS

- .1 Take precautions to protect the environment.
 - .1 Do not proceed until written instructions have been received from Consultant.
- .2 Notify Owner and Consultant in writing, minimum 6 days before disrupting building access or services.

Part 2 Products - Not Used

Part 3 Execution

3.1 EXAMINATION

- .1 Inspect site with Consultant and verify extent and location of items designated for removal, disposal, alternative disposal, recycling, salvage and items to remain.
- .2 Locate and protect utilities. Preserve active utilities traversing site in operating condition.
- .3 Notify and obtain approval of utility companies before starting demolition.
- .4 Disconnect, cap, plug or divert, as required, existing public utilities within the property where they interfere with the execution of the work, in conformity with the requirements of the authorities having jurisdiction. Mark the location of these and previously capped or plugged services on the site and indicate location (horizontal and vertical) on the record drawings. Support, shore up and maintain pipes and conduits encountered.
 - .1 Immediately notify Consultant and utility company concerned in case of damage to any utility or service, designated to remain in place.
 - .2 Immediately notify the Consultant should uncharted utility or service be encountered, and await instruction in writing regarding remedial action.

3.2 PREPARATION

- .1 Temporary Erosion and Sedimentation Control:
 - .1 Provide temporary erosion and sedimentation control measures to prevent soil erosion and discharge of soil-bearing water runoff or airborne dust to adjacent properties and walkways,
 - .2 Remove erosion and sedimentation controls and restore and stabilize areas disturbed during removal after completion of demolition work..
- .2 Protection of In-Place Conditions:
 - .1 Prevent movement, settlement, or damage to adjacent structures, utilities, and landscaping features to remain in place. Provide bracing and shoring required.
 - .2 Keep noise, dust, and inconvenience to occupants to minimum.
 - .3 Protect building systems, services and equipment.
 - .4 Provide temporary dust screens, covers, railings, supports and other protection as required.
 - .5 Do Work in accordance with Section 01 35 29 - Health and Safety Requirements.

- .3 Demolition/Removal:
 - .1 Remove items as indicated.
 - .2 Removal of Pavements, Curbs and Gutters:
 - .1 Square up adjacent surfaces to remain in place by saw cutting or other method approved by Consultant.
 - .2 Protect adjacent joints and load transfer devices.
 - .3 Protect underlying and adjacent granular materials designated to remain.

3.3

CLEANING

- .1 Progress Cleaning: clean in accordance with Section 01 74 11 - Cleaning.
 - .1 Leave Work area clean at end of each day.
- .2 Final Cleaning: upon completion remove surplus materials, rubbish, tools and equipment in accordance with Section 01 74 11 - Cleaning.
- .3 Refer to demolition drawings and specifications for items to be salvaged for reuse.
- .4 Waste Management: separate waste materials for reuse or recycling.
 - .1 Remove recycling containers and bins from site and dispose of materials at appropriate facility.

End Of Section

PART 1 - GENERAL

1.1 Protection

- .1 Prevent damage to existing site features which are to be retained such as fencing, bench marks, trees, landscaping, pavement, utility lines. Make good any damage.

1.2 Site Conditions

- .1 Known underground and surface utility lines and buried objects are indicated on site plan and/or survey plan (approximate only). Contractor shall confirm locations and nature of all existing site services prior to commencement of work.

PART 2 - PRODUCTS- Not Used

PART 3 - EXECUTION

3.1 Preparation

- .1 Inspect site and verify with Consultant items designated to remain, prior to commencement of work.
- .2 Locate and protect utility lines. Preserve in operating condition active utilities traversing site.

3.2 Clearing and Grubbing

- .1 Grub out stumps, roots, rubbish and other non-perishable material over 2" (50 mm) to minimum depth of 2'-0" (600 mm) below indicated finish grade from cleared areas. Remove embedded rocks less than 1 cubic yard (0.25 cubic m) encountered during clearing operations.
- .2 Clear site free of trees, scrub plants, debris, rocks and stumps unless noted to be retained, prior to stripping operation.
- .3 Dispose of cleared and grubbed material by hauling away from site. Pay all fees associated with excess soil material.
- .4 Dispose of all excess materials legally. Pay all fees associated with entry and disposal at landfill site, as necessary.

End Of Section

Part 1 General

1.1 RELATED WORK

- .1 Clearing & Grubbing: Section 31 11 00
- .2 Hydroseeding: Section 32 91 19

1.2 QUALITY ASSURANCE

- .1 Test Reports: certified test reports showing compliance with specified performance characteristics and physical properties.
- .2 Certificates: product certificates signed by manufacturer certifying materials comply with specified performance characteristics and criteria and physical requirements.

1.3 QUALITY CONTROL

- .1 Contractor is responsible for soil analysis and requirements for amendments to supply topsoil as specified.
- .2 Soil testing by recognized testing facility for PH, P and K, and organic matter.

1.4 WASTE MANAGEMENT AND DISPOSAL

- .1 Separate waste materials for reuse and recycling.
- .2 Divert unused soil from landfill.
- .3 Do not dispose of unused soil amendments into sewer systems, into lakes, streams, onto ground or in locations where it will pose health or environmental hazard.

Part 2 Products

2.1 TOPSOIL

- .1 Topsoil for seeded areas: mixture of mineral particulates, micro organisms and organic matter which provides suitable medium for supporting intended plant growth.
 - .1 Soil texture based on The Canadian System of Soil Classification, to consist of 20% to 70% sand, minimum 7% clay, and contain 2 to 10 % organic matter by weight.
 - .2 Contain no toxic elements or growth inhibiting materials.
 - .3 Free from:
 - .1 Debris and stones over 50 mm diameter.
 - .2 Course vegetative material, 10 mm diameter and 100 mm length, occupying more than 2% of soil volume.
 - .4 Consistence: friable when moist.

2.2 SOIL AMENDMENTS

- .1 Fertilizer
 - .1 Fertility: major soil nutrients present in following amounts:
 - .2 Nitrogen (N): 20 to 40 micrograms of available N per gram of topsoil.
 - .3 Phosphorus (P): 40 to 50 micrograms of phosphate per gram of topsoil.
 - .4 Potassium (K): 75 to 110 micrograms of potassium per gram of topsoil.
 - .5 Calcium, magnesium, sulfur and micro-nutrients present in balanced ratios to support germination and/or establishment of intended vegetation.
 - .6 Ph value: 6.5 to 8.0.

- .2 Peatmoss:
 - .1 Derived from partially decomposed species of Sphagnum Mosses.
 - .2 Elastic and homogeneous, brown in colour.
 - .3 Free of wood and deleterious material which could prohibit growth.
 - .4 Shredded particle minimum size: 5 mm.
- .3 Sand: washed coarse silica sand, medium to course textured.
- .4 Limestone:
 - .1 Ground agricultural limestone.
 - .2 Gradation requirements: percentage passing by weight, 90% passing 1.0 mm sieve, 50% passing 0.125 mm sieve.
- .5 Fertilizer: industry accepted standard medium containing nitrogen, phosphorous, potassium and other micro-nutrients suitable to specific plant species or application or defined by soil test.

Part 3 Execution

3.1 STRIPPING OF TOPSOIL

- .1 Do not handle topsoil while in wet or frozen condition or in any manner in which soil structure is adversely affected.
- .2 Commence topsoil stripping of areas as indicated after area has been cleared of brush weeds and grasses and removed from site.
- .3 Strip topsoil to depths as indicated. Avoid mixing topsoil with subsoil where textural quality will be moved outside acceptable range of intended application.
- .4 Stockpile in locations as directed by Owner's Representative. Stockpile height not to exceed 2 m.
- .5 Disposal of unused topsoil.
- .6 Protect stockpiles from contamination and compaction.

3.2 PREPARATION OF EXISTING GRADE

- .1 Verify that grades are correct. If discrepancies occur, notify Owner's Representative and do not commence work until instructed by Owner's Representative.
- .2 Grade soil, eliminating uneven areas and low spots, ensuring positive drainage.
- .3 Remove debris, roots, branches, stones in excess of 50 mm diameter and other deleterious materials. Remove soil contaminated with calcium chloride, toxic materials and petroleum products. Remove debris which protrudes more than 75 mm above surface. Dispose of removed material off site.
- .4 Course cultivate entire area which is to receive topsoil to minimum depth of 100 mm. Cross cultivate those areas where equipment used for hauling and spreading has compacted soil.

3.3 PLACING AND SPREADING OF TOPSOIL/PLANTING SOIL

- .1 Place topsoil after Owner's Representative has accepted subgrade.
- .2 Spread topsoil in uniform layers not exceeding 150 mm, over unfrozen subgrade free of standing water.
- .3 For sodded areas keep topsoil 50/100 mm below finished grade.
- .4 Spread topsoil as indicated to following minimum depths after settlement and 80% compaction:
 - .1 150 mm for seeded areas.
 - .2 135 mm for sodded areas.
 - .3 300 mm for flower beds.
 - .4 500 mm for shrub beds.
- .5 Manually spread topsoil/planting soil around trees, shrubs and obstacles.

- 3.4 FINISH GRADING**
- .1 Grade to eliminate rough spots and low areas and ensure positive drainage. Prepare loose friable bed by means of cultivation and subsequent raking.
 - .2 Consolidate topsoil to required bulk density using equipment approved by Owner's Representative. Leave surfaces smooth, uniform and firm against deep footprinting.
- 3.5 ACCEPTANCE**
- .1 Owner's Representative will inspect and test topsoil in place and determine acceptance of material, depth of topsoil and finish grading. Approval of topsoil material subject to soil testing and analysis.
- 3.6 RESTORATION OF STOCKPILE SITES**
- .1 Restore stockpile sites acceptable to Owner's Representative.
- 3.7 SURPLUS MATERIAL**
- .1 Dispose of materials not required where directed by Owner's Representative.
- 3.8 CLEANING**
- .1 Upon completion of installation, remove surplus materials, rubbish, tools and equipment barriers.

End Of Section

Part 1 General

1.1 RELATED SECTIONS

Topsoil Placement, Fine Grading, Seeding

1.2 SUBMITTALS

- .1 Submit Submittals in accordance with Section 01 33 00 - Submittal Procedures
- .2 Product Data.
 - .1 Provide product data for:
 - .1 Seed.
 - .2 Mulch.
 - .3 Tackifier.
 - .4 Fertilizer

1.3 QUALITY ASSURANCE

- .1 Certificates: product certificates signed by manufacturer certifying materials comply with specified performance characteristics and criteria and physical requirements.
- .2 Pre-Installation Meetings: conduct pre-installation meeting to verify project requirements, installation instructions and warranty requirements.

1.4 SCHEDULING

- .1 Schedule hydraulic seeding to coincide with preparation of soil surface.

1.5 WASTE MANAGEMENT AND DISPOSAL

- .1 Divert unused fertilizer from landfill to official hazardous material collections site as approved by the Ministry of the Environment or governing body.
Do not dispose of unused fertilizer into sewer systems, into lakes, streams or in locations where it will pose health or environmental hazard.

1.6 WARRANTY

- .1 All areas hydroseeded under this contract shall have a warranty period of one (1) year from the date of acceptance and shall cover any defects in materials and workmanship or damages caused by the elements of weather. All defects shall be repaired to the satisfaction of the Consultant at no cost to the Owner.

Part 2 Products

2.1 MATERIALS

- .1 Seed: "Canada pedigreed grade" in accordance with Government of Canada Seeds Act and local regulations
 - .1 Grass mixture composition:
 - .1 50 % Creeping Red Fescue
 - .2 20 % Red Top.
 - .3 15% Canada Blue Grass
 - .4 15 % Kentucky Blue Grass
- .2 Mulch: specially manufactured for use in hydraulic seeding equipment, non-toxic, water activated, green colouring, free of germination and growth inhibiting factors with following properties:
 - .1 Type I mulch:
 - .1 Made from wood cellulose fibre.
 - .2 Organic matter content: 95% plus or minus 0.5%.

- .3 Value of pH: 6.0.
- .4 Potential water absorption: 900%.
- .2 Type II mulch: straw.
- .3 Use either Type I or Type II mulch.
- .3 Tackifier: water dilutable, liquid dispersion or water soluble vegetable carbohydrate powder.
- .4 Water: free of impurities that would inhibit germination and growth.
- .5 Fertilizer:
 - .1 To Canada "Fertilizers Act" and "Fertilizers Regulations".
 - .2 Complete synthetic, slow release with 35% of nitrogen content in water insoluble form.
- .6 Imported Topsoil: friable, neither heavy clay or of very light sandy nature, containing a minimum of 4% organic matter for clay loams and 2% for sandy loams to a maximum of 20% volume. Free from subsoil, roots, grass, weeds, toxic materials, stones, foreign objects and with an acidity range, PH of 5.5 to 7.5. Topsoil containing crabgrass, couchgrass or noxious weeds is not acceptable.

Part 3 Execution

3.1 WORKMANSHIP

- .1 Do not spray onto structures, signs, guide rails, fences, plant material, utilities and other than surfaces intended.
- .2 Clean-up immediately, any material sprayed where not intended, to satisfaction of Consultant.
- .3 Do not perform work under adverse field conditions such as wind speeds over 10 km/h, frozen ground or ground covered with snow, ice or standing water. Protect seeded areas from trespass until plants are established.

3.2 PREPARATION OF SURFACES AND PLACEMENT OF TOPSOIL

- .1 Fine grade subgrade to eliminate uneven areas, low spots and ensure positive drainage. Remove debris, roots, branches, stones in excess of 2" (50 mm) diameter and deleterious materials. Obtain review prior to placing topsoil.
- .2 Spread topsoil evenly over area to be seeded to minimum thickness of 4" (100 mm).
- .3 Fine grade entire topsoil to eliminate uneven areas and low spots. Ensure positive drainage and provide a uniform, smooth finish.
- .2 Roll topsoil with 110 lb (50 kg) roller, minimum 36" (900 mm) wide to compact and retain surface.
- .2 Cultivate area to be seeded to depth of 1" (25 mm).
- .3 Ensure areas to be seeded are moist to depth of 6" (150mm) before seeding.

3.3 FERTILIZING PROGRAM

- .1 Fertilize prior to fine grading, equally distributed.

3.4 PREPARATION OF SLURRY

- .1 Measure quantities of materials by weight or weight-calibrated volume measurement satisfactory to Consultant. Supply equipment required for this work.
- .2 Charge required water into seeder. Add material into hydraulic seeder under agitation. Pulverize mulch and charge slowly into seeder.
- .3 After all materials are in the seeder and well mixed, charge tackifier into seeder and mix thoroughly to complete slurry.

3.5 SLURRY APPLICATION

- .1 Hydraulic seeding equipment:
 - .1 Slurry tank.
 - .2 Agitation system for slurry to be capable of operating during charging of tank and during seeding, consisting of recirculation of slurry and/or mechanical agitation method.
 - .3 Capable of seeding by 165' (50 m) hand operated hoses and appropriate nozzles.
 - .4 Tank volume to be certified by certifying authority and identified by authorities "Volume Certification Plate".
- .2 Slurry mixture applied per hectare.
 - .1 Seed: Grass mixture 330 lb (150 kg).
 - .2 Mulch: Type I or II 2755 lb (1250 kg).
 - .3 Tackifier: 44 lb (20 kg).
 - .4 Water: Minimum 6600 imp. gal. (30,000 L).
 - .5 Fertilizer: 1323 lb (600 kg), ratio 5:20:10
- .3 Apply slurry uniformly, at optimum angle of application for adherence to surfaces and germination of seed.
 - .1 Using correct nozzle for application.
 - .2 Using hoses for surfaces difficult to reach and to control application.
- .4 Blend application 12" (300 mm) into adjacent grass areas to form uniform surfaces.
- .5 Re-apply where application is not uniform.
- .6 Remove slurry from items and areas not designated to be sprayed.
- .7 Protect seeded areas from trespass satisfactory to Consultant
- .8 Remove protection devices as directed by Consultant.

3.6 MAINTENANCE DURING ESTABLISHMENT PERIOD

- .1 Perform following operations from time of seed application until acceptance by Consultant.
- .2 Grass Mixture:
 - .1 Repair and reseed dead or bare spots to allow establishment of seed prior to acceptance.
 - .2 Mow grass to 2" (50 mm) whenever it reaches height of 2 3/4" (70 mm). Remove clippings which will smother grass.
 - .3 Fertilize seeded areas 10 weeks after germination provided plants have mature true leaves. Spread half of required amount of fertilizer in one direction and remainder at right angles; water in well. Date and time of fertilization must be approved by Owner prior to execution.
 - .4 Control weeds by mechanical or chemical means utilizing acceptable integrated pest management practices. If chemical means are to be utilized, the date and time of weed control must be approved by Owner prior to execution.
 - .5 Contractor to water seeded area to maintain optimum soil moisture level for germination and continued growth of grass for a minimum of 10 weeks after time of seeding. Control watering to prevent washouts.

3.7 ACCEPTANCE

- .1 Seeded areas will be accepted by Consultant provided that:
 - .1 Plants are uniformly established. Seeded areas are free of rutted, eroded, bare or dead spots.
 - .2 Areas have been mown at least twice.
 - .3 Areas have been fertilized.
- .2 Areas seeded in fall will achieve final acceptance in following spring, one month after start of growing season provided acceptance conditions are fulfilled.

3.8 MAINTENANCE DURING WARRANTY PERIOD

- .1 Perform following operations from time of acceptance until end of warranty period:
 - .1 Repair and reseed dead or bare spots to satisfaction of Consultant.
 - .2 Fertilize seeded areas in accordance with fertilizing program. Spread half of required amount of fertilizer in one direction and remainder at right angles and water in well.

3.9 CLEANING

- .1 Upon completion of installation, remove surplus materials, rubbish, tools and equipment barriers.

End Of Section

CLIENT:
ST. CLAIR CATHOLIC DISTRICT SCHOOL BOARD
 420 CREEK ST.
 WALLACEBURG, ON
 N8A 4C4

PURPOSE OF SUBMISSION	MM.DD.YEAR
ISSUED FOR BIDS	05.24.2019
ISSUED FOR CLIENT REVIEW	05.15.2019



PROJECT:
GOOD SHEPHERD CATHOLIC SCHOOL
PLAYGROUND ASPHALT REPLACEMENT
 4 EDITH ST.
 THAMESVILLE, ONTARIO
 CLIENT#:642-CP1917

GENERAL INFORMATION DRAWING LIST		ARCHITECTURAL DRAWING LIST	
DRAWING	DRAWING DESIGNATION	DRAWING	DRAWING DESIGNATION
GENERAL	COVER PAGE	AD101	ARCHITECTURAL DEMOLITION SITE PLANS, ENLARGED SITE PLAN
	PROJECT ID DRAWING INDEX CONSULTANT MATRIX	A101	ARCHITECTURAL NEW CONSTRUCTION SITE PLANS, ENLARGED SITE PLAN
CIVIL DRAWING LIST			
DRAWING	DRAWING DESIGNATION		
CIVIL	C-1		
	C-2		
	SITE PLAN		
	GENERAL INFORMATION		

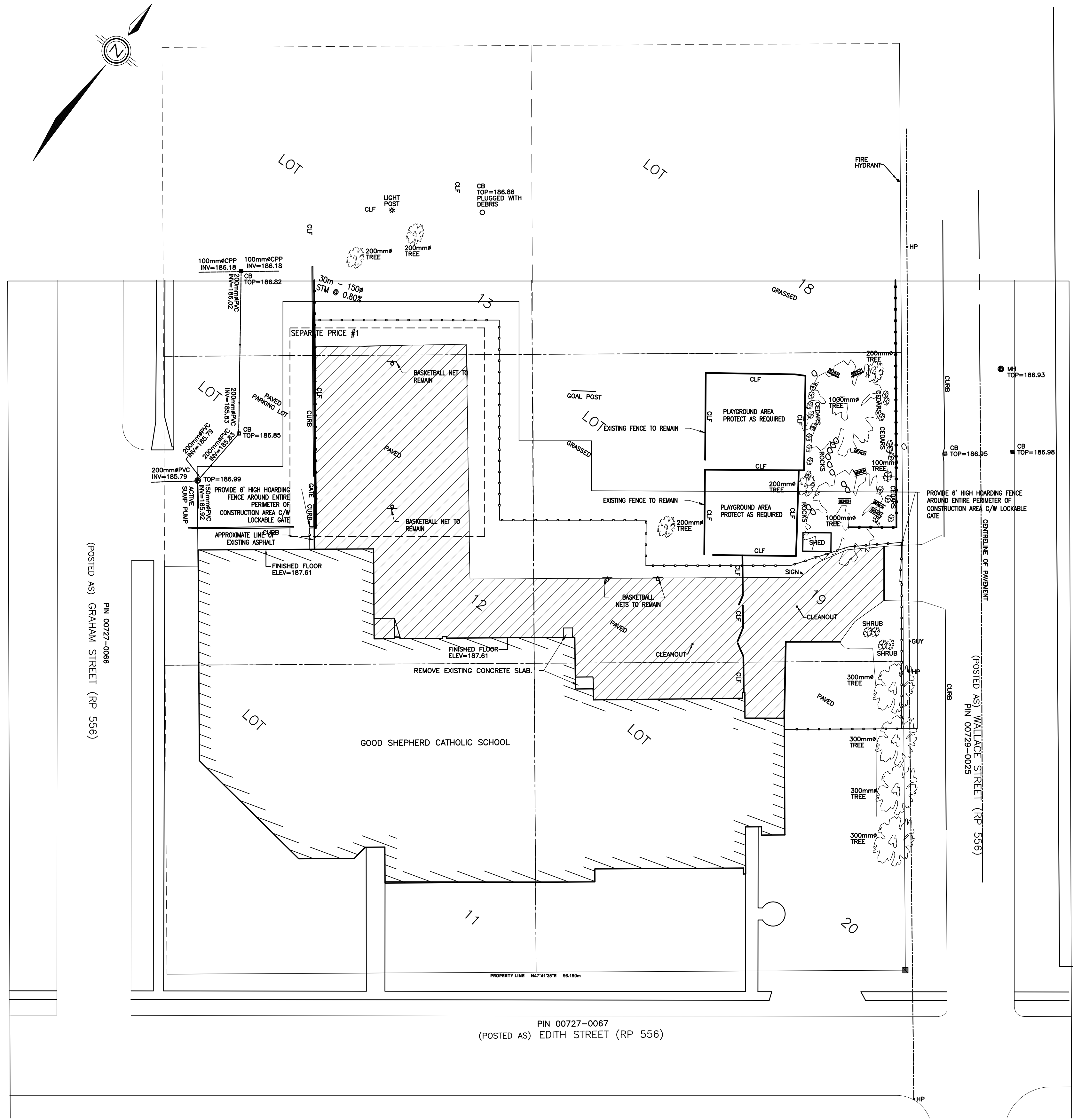
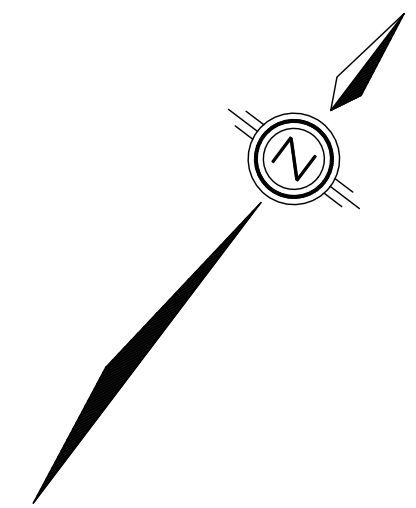

- GENERAL NOTES:**
1. ALL WORK SHALL BE CARRIED OUT IN ACCORDANCE WITH THE ONTARIO BUILDING CODE, PLUMBING CODE, ONTARIO REGULATION 815/84, AND THE MUNICIPALITY OF CHATHAM-KENT STANDARDS.
 2. ALL WORK INSIDE PROPERTY SHALL MEET THE REQUIREMENTS OF THE MUNICIPALITY OF CHATHAM-KENT BUILDING DEPARTMENT.
 3. ALL WORK OUTSIDE PROPERTY SHALL MEET THE REQUIREMENTS OF THE MUNICIPALITY OF CHATHAM-KENT PUBLIC WORKS DEPARTMENT.
 4. RESTORE ALL SURFACES TO A CONDITION EQUAL TO OR BETTER THAN ORIGINAL AND TO THE SATISFACTION OF ST. CLAIR CATHOLIC DISTRICT SCHOOL BOARD.
 5. THE LOCATION OF UNDERGROUND AND ABOVE GROUND UTILITIES AND STRUCTURES ARE NOT NECESSARILY SHOWN ON THESE DRAWINGS, AND WHERE SHOWN, THE LOCATIONS MAY NOT BE ACCURATE. PRIOR TO STARTING THE WORK, THE CONTRACTOR SHALL ASCERTAIN EXACT LOCATIONS OF ALL UTILITIES AND STRUCTURES AND ASSUME LIABILITY FOR ANY DAMAGES.
 6. ALL SEWERS SHALL BE PVC SDR 35 PIPE, UNLESS NOTED OTHERWISE.
 7. SEWER BEDDING SHALL BE CLASS 'B'. THE FIRST PIPE AT THE MANHOLE SHALL NOT EXCEED 1.0m.
 8. BENCHING IS NOT REQUIRED IN STORM MANHOLES. PROVIDE A MINIMUM OF 300mm AND A MAXIMUM OF 450mm DEEP SUMP.
 9. ALL SEWERS AND WATER SERVICES UNDER THE PAVEMENT SHALL BE BACKFILLED WITH GRANULAR 'A' TO 100% S.P.M.D.D. AND WITH APPROVED NATIVE MATERIAL TO 95% S.P.M.D.D. ELSEWHERE.
 10. EXTEND BACKFILL FOR SEWERS CROSSING PAVEMENT TO 450mm BEYOND FACE OF CURB.
 11. ALL CATCH BASINS SHALL BE EQUIPPED WITH 150mm PVC SDR 35 LEADS, UNLESS NOTED OTHERWISE.
 12. ALL MANHOLES TO BE 1200mm DIAMETER AS PER OPSD 701.010, UNLESS OTHERWISE NOTED.
 13. PROVIDE CLEANOUTS ALONG 150mm PIPES AT A MINIMUM SPACING OF 30.0m.
 14. CLEAN-OUTS IN PAVED AREAS SHALL BE SURROUNDED IN 150mm CONCRETE. COVERS SHALL BE HEAVY DUTY METAL.
 15. PAVEMENT GRADES SHOWN ARE AT CATCH BASINS OR AT EDGE OF PAVEMENT.
 16. RADII DIMENSIONS AND PAVEMENT WIDTHS SHOWN ARE TO THE EDGE OF PAVEMENT.
 17. SAWCUT EDGE OF EXISTING ASPHALT PAVEMENT TO MEET NEW ASPHALT, WHERE NECESSARY.
 18. JOINT SPACING FOR CONCRETE CURB SHALL BE EVERY 3.0m MAXIMUM.
 19. ANY FILL SHALL BE APPROVED NATIVE MATERIAL.
 20. THE CONTRACTOR SHALL DISPOSE OF REMOVED AND EXCESS MATERIAL OFF SITE IN A SUITABLE MANNER.
 21. ALL CATCHBASINS/MANHOLE CATCHBASINS TO BE EQUIPPED WITH 100mm DIA. SUBDRAIN WITH FILTER SOCK, INSTALLED IN FOUR DIRECTIONS EACH 3.0m IN LENGTH, TRENCHED IN THE SUBGRADE.
 22. ALL PERFORATED PIPE TO BE CAPPED AT UPSTREAM END.
 23. THE ELEVATIONS OF ALL EXISTING UTILITY COVERS/APPURTENANCES SHALL BE ADJUSTED TO MEET THE PROPOSED GRADES. THIS SHALL INCLUDE, BUT NOT BE LIMITED TO THE FOLLOWING: MANHOLES, CLEANOUTS, VALVES, ETC.
 24. THE CONTRACTOR SHALL SUBMIT A CERTIFICATE BY AN ONTARIO LAND SURVEYOR OR ENGINEER STATING THAT THE GRADES CONFORM TO THE GRADES SHOWN ON THE APPROVED DRAWINGS AT THE COMPLETION OF CONSTRUCTION.

- SEDIMENT CONTROL MEASURES:**
1. THE CONTRACTOR SHALL PROTECT ALL EXPOSED SURFACES AND CONTROL ALL RUNOFF DURING CONSTRUCTION.
 2. ALL EROSION CONTROL MEASURES SHALL BE IN PLACE PRIOR TO STARTING CONSTRUCTION AND MUST REMAIN IN PLACE UNTIL RESTORATION IS COMPLETE.
 3. THE CONTRACTOR SHALL MAINTAIN EROSION CONTROL MEASURES DURING CONSTRUCTION.
 4. ALL COLLECTED SEDIMENT SHALL BE DISPOSED OF AT AN APPROVED LOCATION.
 5. AREA DISTURBED DURING CONSTRUCTION SHALL BE KEPT TO A MINIMUM.
 6. ALL DE-WATERING SHALL BE DISPOSED OF IN AN APPROVED SEDIMENTATION BASIN.
 7. THE CONTRACTOR SHALL PROTECT ALL CATCHBASINS, MANHOLES AND PIPE ENDS FROM SEDIMENT INTRUSION WITH FILTER CLOTH OR OTHER APPROVED METHOD.
 8. ALL SUMPS SHALL BE KEPT CLEAN DURING CONSTRUCTION.
 9. THE CONTRACTOR SHALL PREVENT WIND-BLOWN DUST.
 10. STRAW BALES ARE TO BE USED DURING CONSTRUCTION, AS REQUIRED.

(POSTED AS) GRAHAM STREET (RP 556)
PIN 00727-0086

(POSTED AS) WALLACE STREET (RP 556)
PIN 00729-0025

PIN 00727-0067
(POSTED AS) EDITH STREET (RP 556)

NOTES	PROJECT IDENTIFICATION	DRAWING IDENTIFICATION	ORIENTATION	SUB-CONSULTANT	PRIME CONSULTANT	DISCIPLINE SEAL	DRAWING SUBMISSION(S)	INTERNAL INFO	COPYRIGHT 2019									
<p>THE CONTRACTOR SHALL CHECK AND VERIFY ALL DIMENSIONS AND REPORT ANY ERRORS OR OMISSIONS TO THE ARCHITECT PRIOR TO COMMENCING OR PROCEEDING WITH ANY WORK ON THIS PROJECT. ALL DRAWINGS AND SPECIFICATIONS ARE THE PROPERTY OF THE ARCHITECT. THESE DRAWINGS AND SPECIFICATIONS ARE DESIGNED FOR THE CLIENT AND THE PROPERTY INDICATED ON THESE DRAWINGS ONLY AND SHALL NOT BE CONSTRUCTED FOR ANY OTHER CLIENT OR ANY OTHER PROPERTY. DO NOT SCALE DRAWINGS.</p>	<p>GOOD SHEPHERD CATHOLIC SCHOOL ASPHALT REPLACEMENT 4 EDITH ST. THAMESVILLE, ONTARIO N0P 2K0</p> <p>DESIGN REVIEW SITE PLAN APPROVAL BUILDING PERMIT BIDS DOCUMENTS CONTRACT DOCUMENTS CONSTRUCTION DOCUMENTS</p>	<p>DEMOLITION PLAN AND MISCELLANEOUS NOTES</p>		<p>HADDAD MORGAN & ASSOCIATES LTD CONSULTING ENGINEERS 24 Shepherd St. E. Windsor, ON N8X 3P8 (519) 973-1177 hma@haddadmorgan.com</p>	<p>ROA STUDIO 67 KING STREET WEST, CHATHAM ON N7M 1C7 TEL . 519.397.0943 EMAIL . email@roastudio.com</p>		<table border="1"> <tr><td>2</td><td>ISSUED FOR BIDS</td><td>05.24.2019</td></tr> <tr><td>1</td><td>ISSUED FOR OWNER'S 89% REVIEW</td><td>05.16.2019</td></tr> <tr><td>NO.</td><td>DESCRIPTION</td><td>DATE</td></tr> </table>	2	ISSUED FOR BIDS	05.24.2019	1	ISSUED FOR OWNER'S 89% REVIEW	05.16.2019	NO.	DESCRIPTION	DATE	<p>CIVIL</p> <p>PROJECT ID: HMA 19-211 DRAWN BY: Z.M. REVIEWED BY: W.T. DATE: 05.24.2019 SCALE: AS NOTED</p>	<p>C101</p>
2	ISSUED FOR BIDS	05.24.2019																
1	ISSUED FOR OWNER'S 89% REVIEW	05.16.2019																
NO.	DESCRIPTION	DATE																

LEGEND

- 150 ST PROPOSED STORM SEWER
- PROPERTY LINE
- INV. xxx.xx PROPOSED INVERT ELEVATION
- MH PROPOSED MANHOLE
- CBMH PROPOSED CATCH BASIN-MANHOLE
- CB PROPOSED CATCH BASIN
- SPCB PROPOSED 450mm x 600mm DEEP SUMP PIT CATCH BASIN
- XXXXXX PROPOSED GRADE
- XXX.XX PROPOSED TOP OF CURB
- C.O. PROPOSED CLEAN-OUT
- t.c. TOP OF CONCRETE CURB
- t.c.a. TOP OF CATCH BASIN
- E/P EDGE OF PAVEMENT
- HP. HIGH POINT
- ▽ PROPOSED DOOR LOCATION

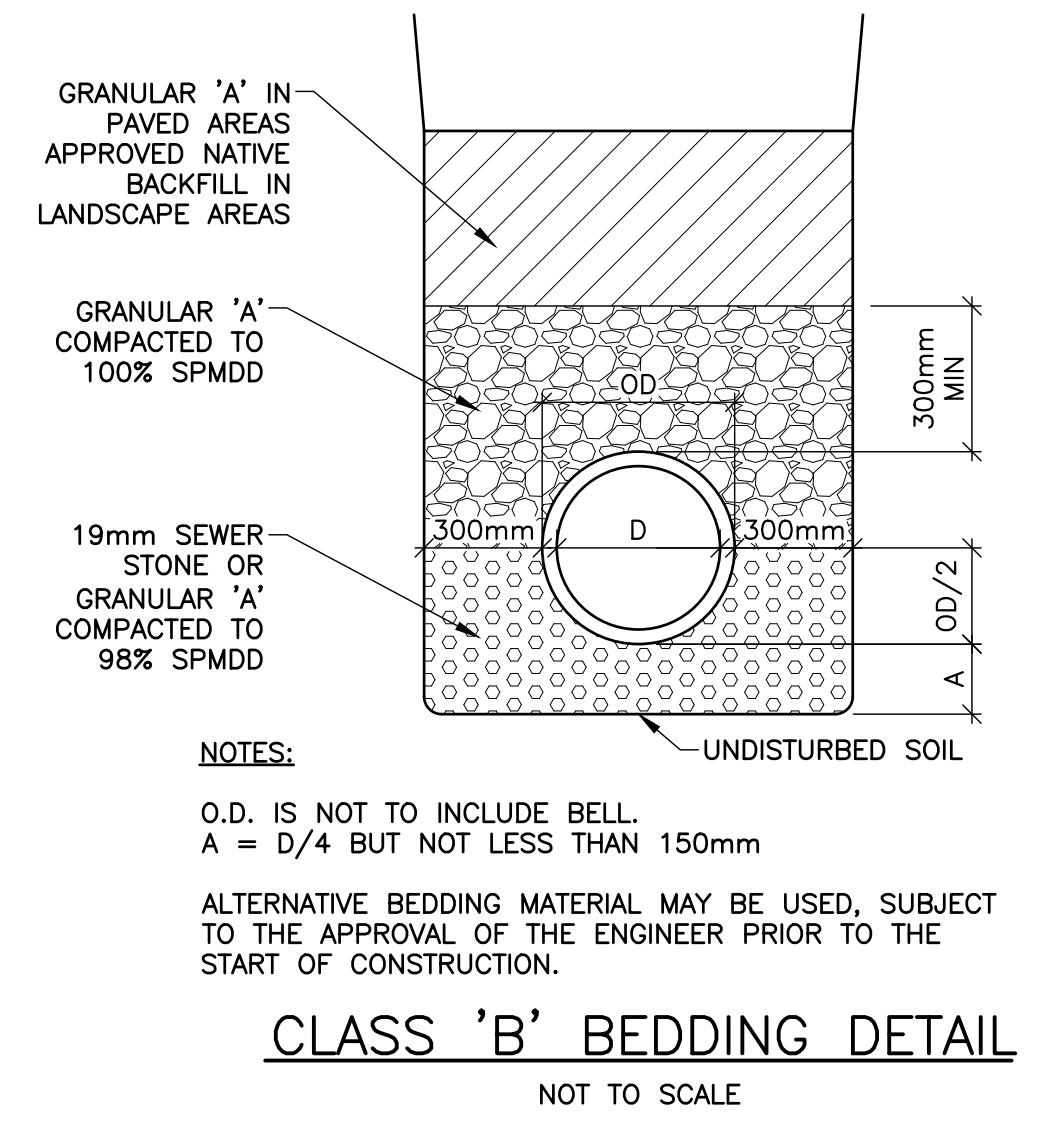
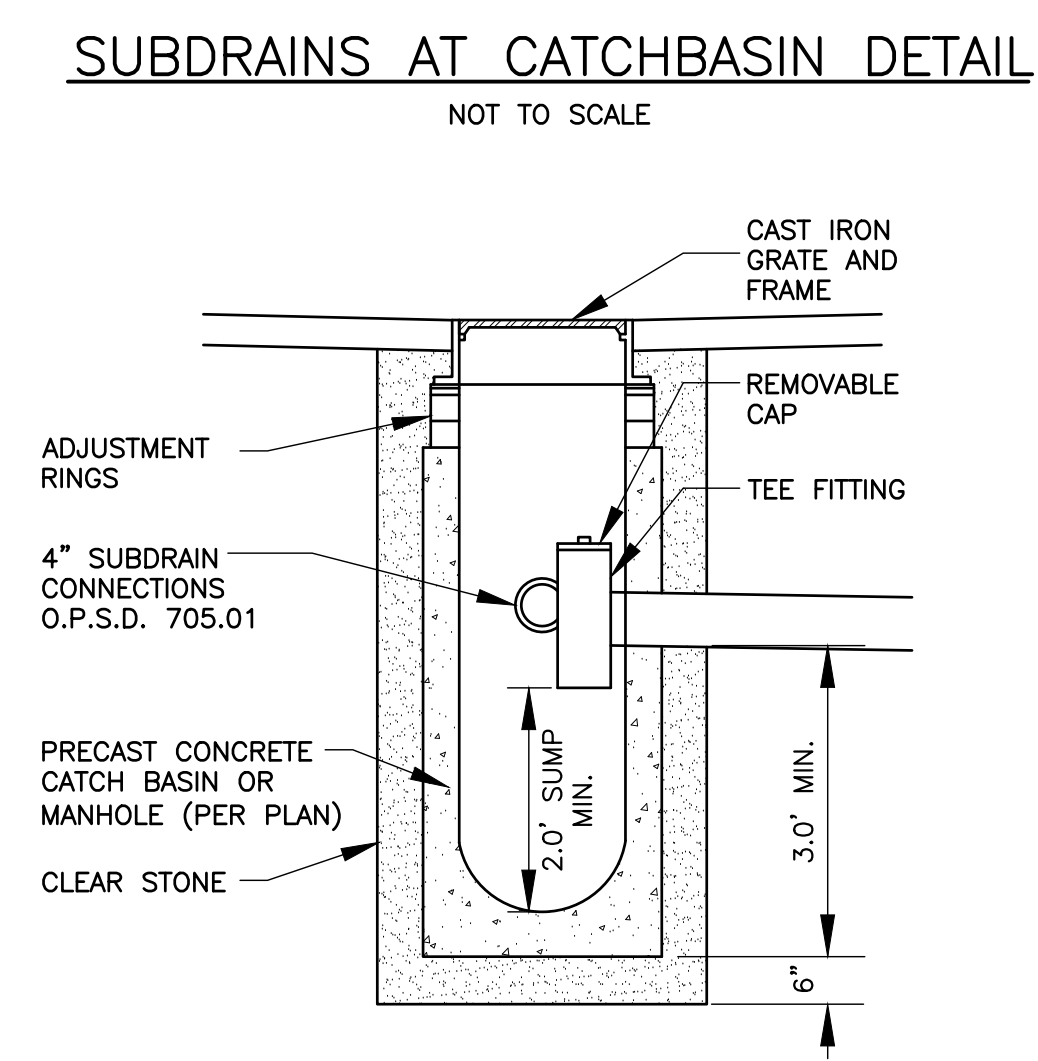
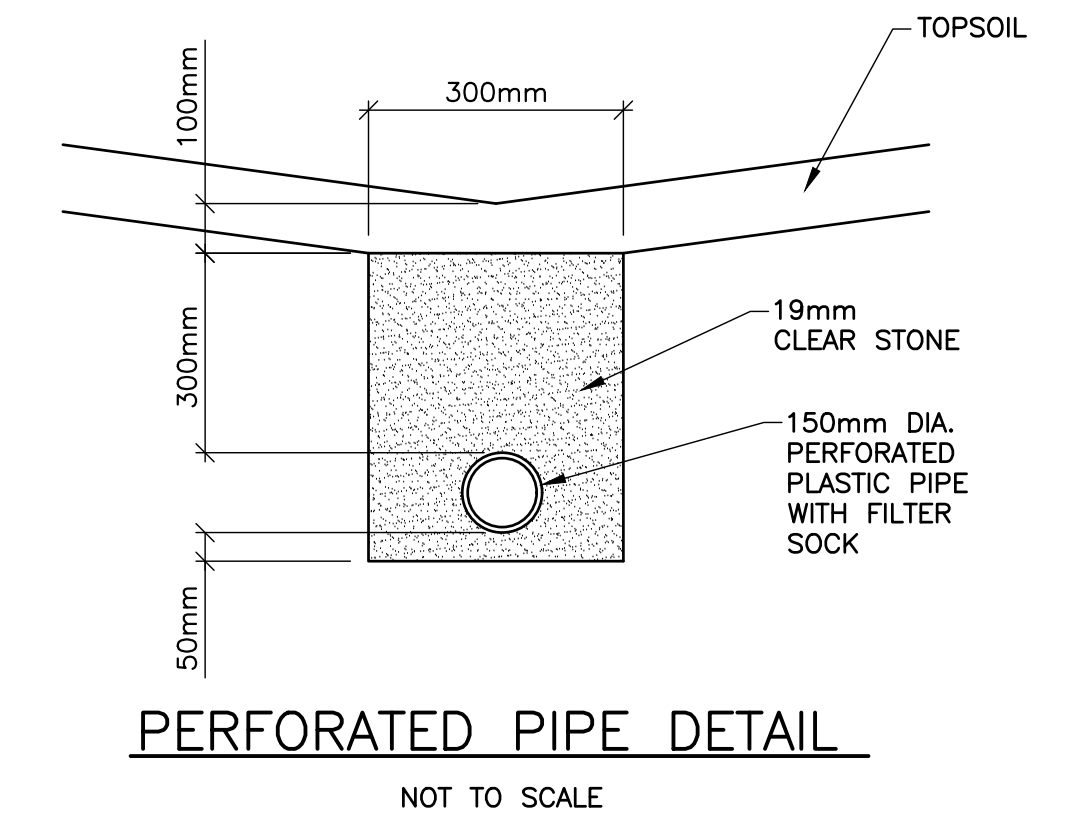
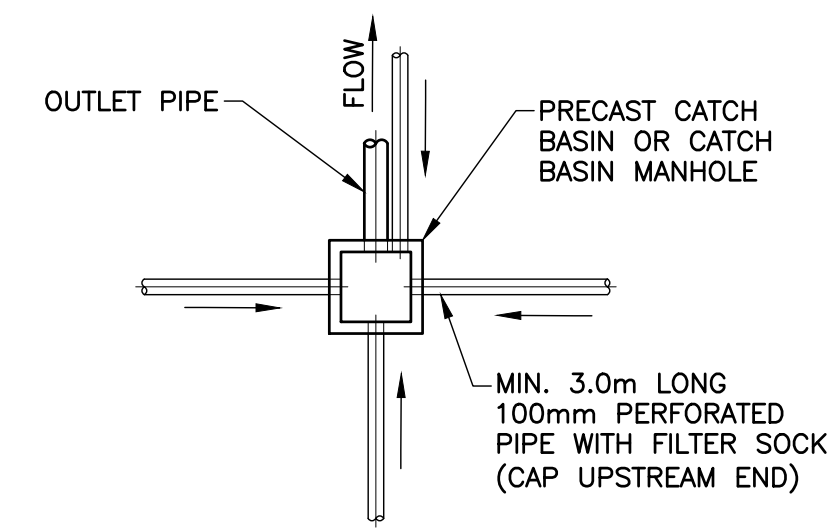
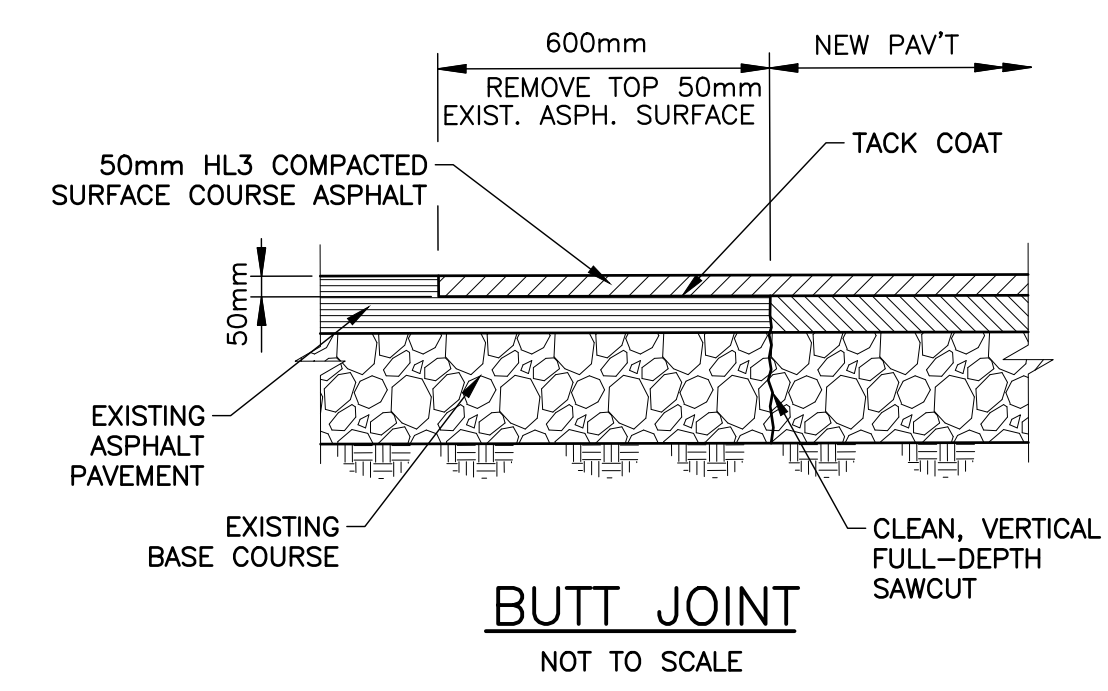
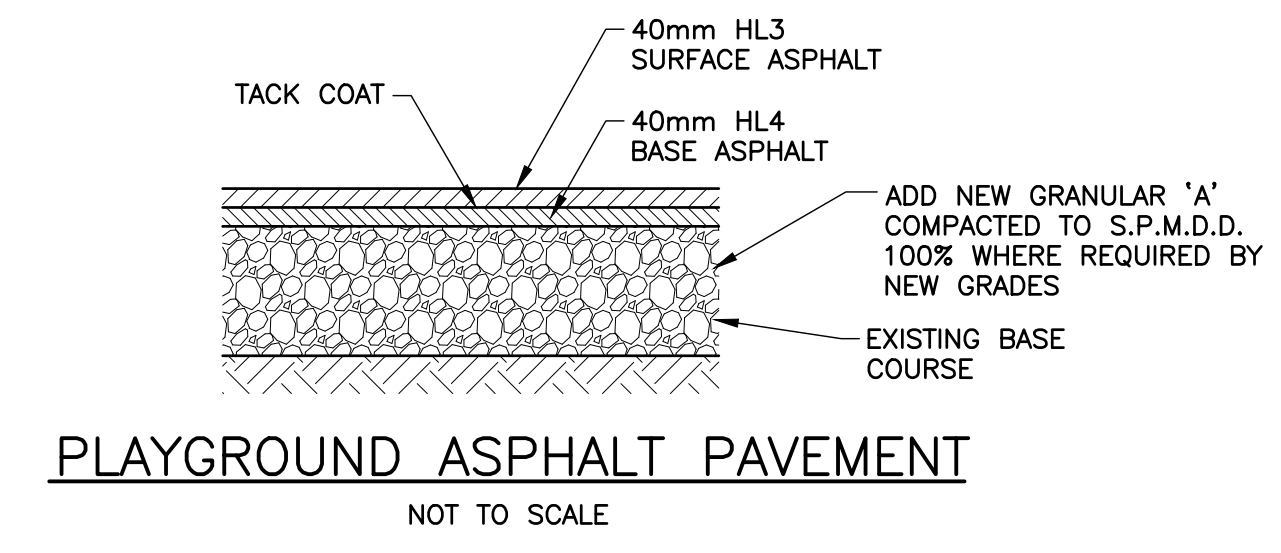

NOTES:
 O.D. IS NOT TO INCLUDE BELL.
 A = D/4 BUT NOT LESS THAN 150mm
 ALTERNATIVE BEDDING MATERIAL MAY BE USED, SUBJECT TO THE APPROVAL OF THE ENGINEER PRIOR TO THE START OF CONSTRUCTION.

CAUTION
 UNDERGROUND UTILITIES AND SERVICES SHOWN ON THIS PLAN ARE APPROXIMATE AND MUST BE VERIFIED BEFORE CONSTRUCTION

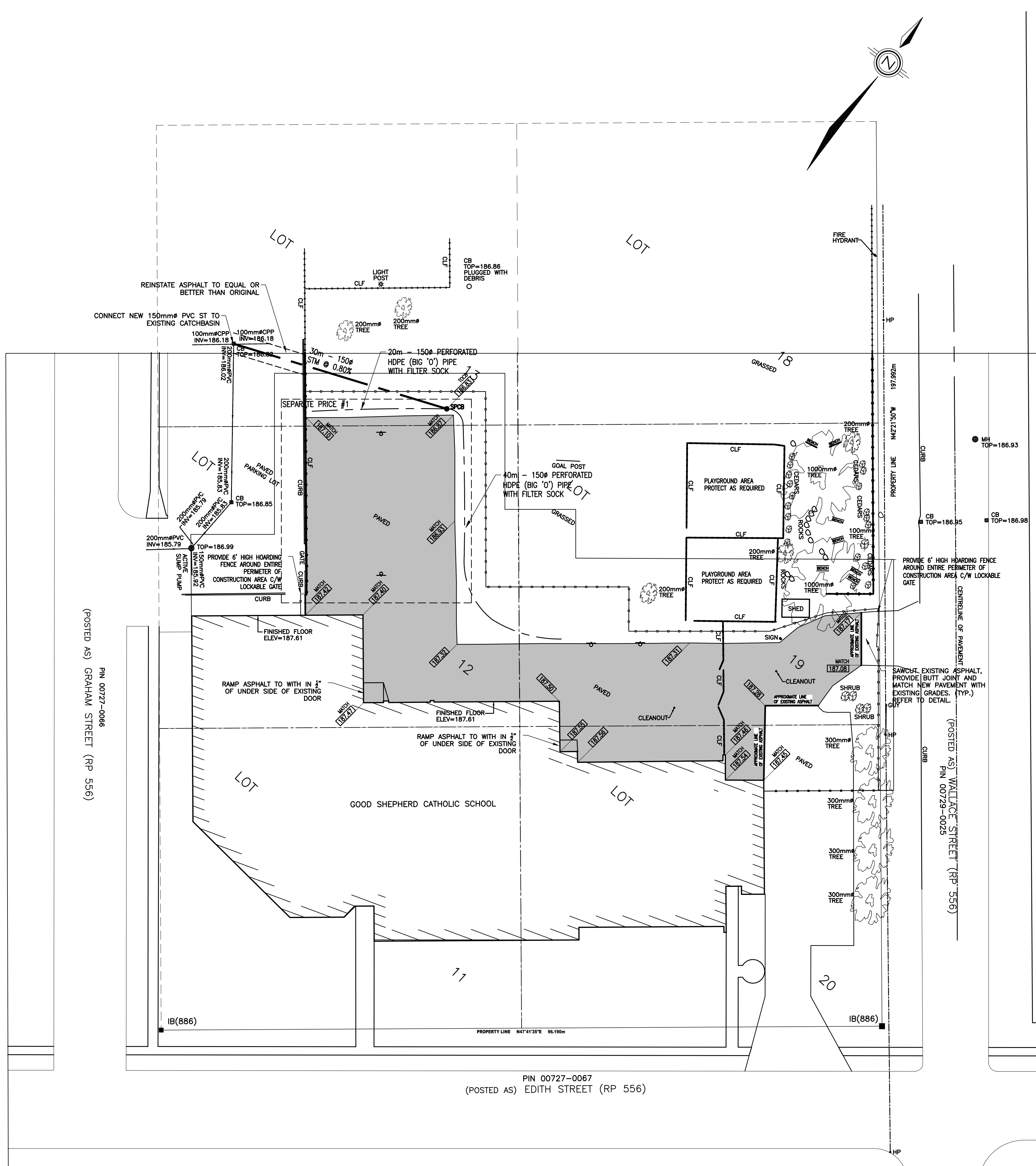

NOTES	PROJECT IDENTIFICATION	DRAWING IDENTIFICATION	ORIENTATION	SUB-CONSULTANT	PRIME CONSULTANT	DISCIPLINE SEAL	DRAWING SUBMISSION(S)	INTERNAL INFO	COPYRIGHT 2019									
<p>THE CONTRACTOR SHALL CHECK AND VERIFY ALL DIMENSIONS AND REPORT ANY ERRORS OR OMISSIONS TO THE ARCHITECT PRIOR TO COMMENCING OR PROCEEDING WITH ANY WORK ON THIS PROJECT. ALL DRAWINGS AND SPECIFICATIONS ARE THE PROPERTY OF THE ARCHITECT. THESE DRAWINGS AND SPECIFICATIONS ARE DESIGNED FOR THE CLIENT AND THE PROPERTY INDICATED ON THESE DRAWINGS ONLY AND SHALL NOT BE CONSTRUCTED FOR ANY OTHER CLIENT OR ANY OTHER PROPERTY. DO NOT SCALE DRAWINGS.</p>	<p>GOOD SHEPHERD CATHOLIC SCHOOL ASPHALT REPLACEMENT 4 EDITH ST. THAMESVILLE, ONTARIO N0P 2K0</p>	<p>DEMOLITION PLAN AND MISCELLANEOUS NOTES</p>					<table border="1"> <tr><td>2</td><td>ISSUED FOR BIDS</td><td>05.24.2019</td></tr> <tr><td>1</td><td>ISSUED FOR OWNER'S 99% REVIEW</td><td>05.16.2019</td></tr> <tr><td>NO.</td><td>DESCRIPTION</td><td>DATE</td></tr> </table>	2	ISSUED FOR BIDS	05.24.2019	1	ISSUED FOR OWNER'S 99% REVIEW	05.16.2019	NO.	DESCRIPTION	DATE	<p>CIVIL</p> <p>PROJECT ID: HMA 19-211 DRAWN BY: Z.M. REVIEWED BY: W.T. DATE: 05.24.2019 SCALE: AS NOTED</p>	<p>C102</p>
2	ISSUED FOR BIDS	05.24.2019																
1	ISSUED FOR OWNER'S 99% REVIEW	05.16.2019																
NO.	DESCRIPTION	DATE																

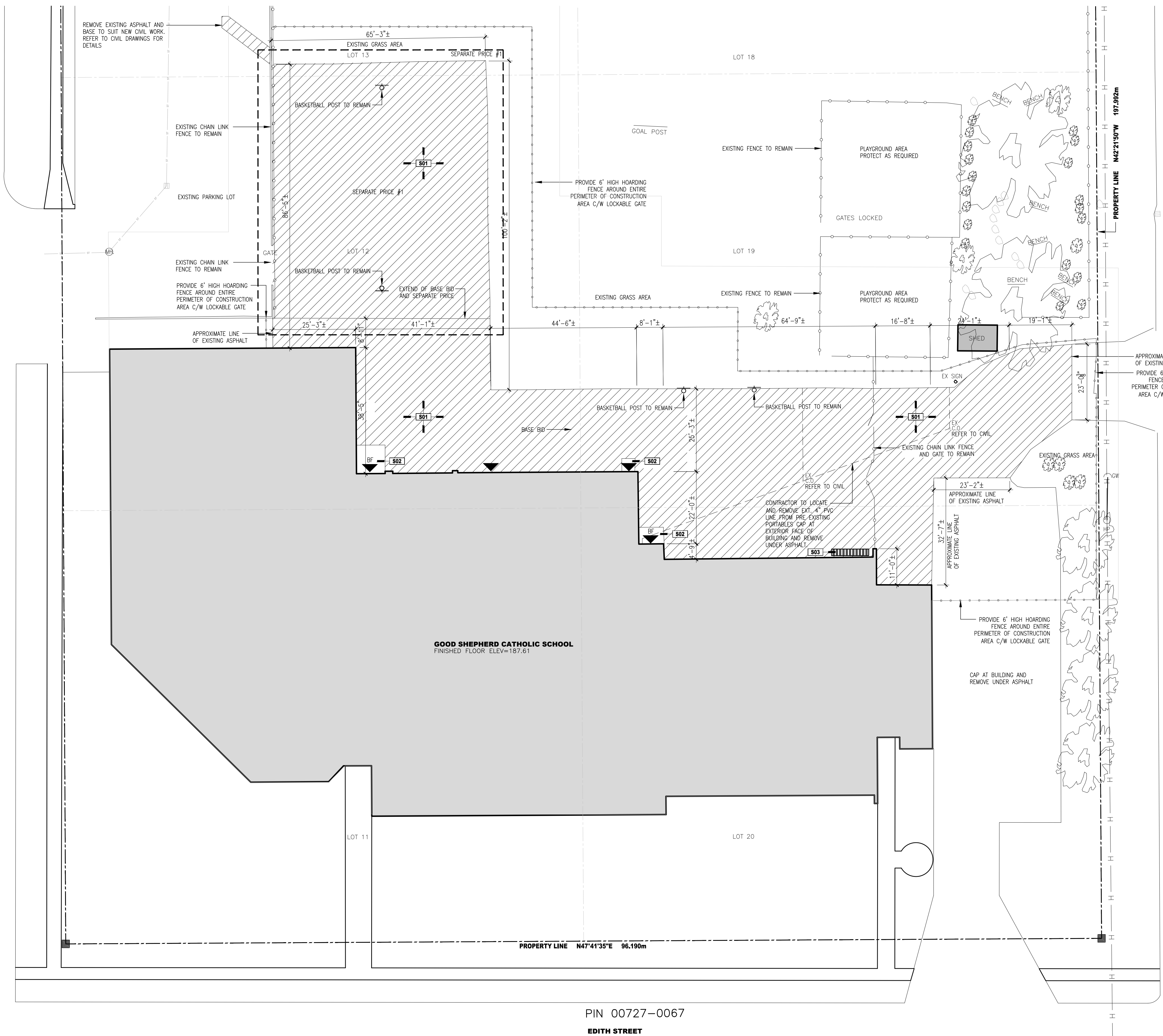

SITE KEY PLAN



SITE DEMOLITION NOTES

- S01** SAW-CUT AND REMOVE EXISTING ASPHALT, RE-GRADE AND COMPACT EXISTING BASE. REFER TO CIVIL FOR ADDITIONAL CONSTRUCTION NOTES.
- S02** REMOVE EXISTING CONCRETE SLAB COMPLETE.
- S03** REMOVE EXISTING BIKE RACK, STORE AND REINSTALL ONCE ASPHALT WORK IS COMPLETE.

SITE CONSTRUCTION NOTES

- S01** INSTALL NEW ASPHALT PAVING ON EXISTING COMPACTED GRANULAR BASE. REFER TO CIVIL DRAWINGS FOR ADDITIONAL DETAILS AND GRADES.
- S02** AFTER INSTALLATION OF NEW ASPHALT, RE-GRADE & HYDROSEED DAMAGED AREAS.
- S03** RAMP ASPHALT TO WITH IN 1/2" OF UNDER SIDE OF EXISTING DOOR. REFER TO CIVIL.
- S04** INSTALL EMERGED GALVANIZED METAL SLEEVE INSERT FOR GATE LOCKING PINS.

GENERAL SITE NOTES

1. THIS DRAWING SHALL BE READ IN CONJUNCTION WITH THE CIVIL DRAWINGS AND THE SPECIFICATIONS. ALL WORK TO BE COORDINATED AND VERIFIED PRIOR TO CONSTRUCTION.
2. THE CONTRACTOR IS RESPONSIBLE FOR VISITING THE SITE TO VERIFY ALL SITE DIMENSIONS, SPOT ELEVATIONS AND REPORT AND DISCREPANCIES TO THE CONSULTANTS PRIOR TO CONSTRUCTION.
3. REPLACE, REPAIR AND MAKE GOOD ALL EXISTING CONCRETE SIDEWALKS, GRASSED AND MULCHED AREAS THAT ARE DAMAGED AS A RESULT OF THIS WORK. THIS INCLUDES ANY AREAS DAMAGED OUTSIDE THE LIMITS OF THE CONTRACT. CONTRACTOR TO DOCUMENT EXISTING SITE CONDITIONS WITH PHOTOGRAPHS PRIOR TO CONSTRUCTION.
4. CONTRACTOR IS RESPONSIBLE FOR MAINTAINING ACCESS AND EGRESS TO ALL EXISTING BUILDING, WALKWAYS, LANES ROADS AND PARKING LOTS IN THE SURROUNDING AREA.
5. CONTRACTOR IS RESPONSIBLE FOR REMOVAL OF ALL DEMOLISHED MATERIALS AND DEBRIS FROM THE SITE. ALL SALVAGED MATERIAL TO BE PROTECTED AND STORED UNTIL REUSE OR TURNED OVER TO OWNER.

SITE SYMBOL LEGEND

SYMBOL	DESCRIPTION	SYMBOL	DESCRIPTION	SYMBOL	DESCRIPTION
[Symbol]	CONSTRUCTION NOTE	[Symbol]	NEW CONCRETE	[Symbol]	EXISTING BUILDING
[Symbol]	DEMOLITION NOTE	[Symbol]	FIRE DEPT CONNECTION	[Symbol]	ENTRANCE EXIT
[Symbol]	EX CATCH BASIN	[Symbol]	EXISTING TREE	[Symbol]	BARRIER FREE ENTRANCE EXIT
[Symbol]	GUIDE WIRE	[Symbol]	EXISTING HYDRO POLE	[Symbol]	HYDRO LINE REFER TO CIVIL DRAWINGS
[Symbol]	NORTH ARROW	[Symbol]	PROPERTY LINE	[Symbol]	EXISTING CLEAN OUT
[Symbol]	PROPERTY IRON BAR	[Symbol]	CATCH BASIN REFER TO CIVIL DRAWINGS	[Symbol]	MANHOLE REFER TO CIVIL DRAWINGS
		[Symbol]	VEGETATION		

01 DEMOLITION SITE PLAN

AD101 SCALE: 1/16" = 1'-0"

NOTES	PROJECT IDENTIFICATION	DRAWING IDENTIFICATION	ORIENTATION	SUB-CONSULTANT	PRIME CONSULTANT	DISCIPLINE SEAL	DRAWING SUBMISSION(S)	INTERNAL INFO	COPYRIGHT 2019									
<p>THE CONTRACTOR SHALL CHECK AND VERIFY ALL DIMENSIONS AND REPORT ANY ERRORS OR OMISSIONS TO THE ARCHITECT PRIOR TO COMMENCING OR PROCEEDING WITH ANY WORK ON THIS PROJECT. ALL DRAWINGS AND SPECIFICATIONS ARE THE PROPERTY OF THE ARCHITECT COPYRIGHT 2019. THESE DRAWINGS AND SPECIFICATIONS ARE DESIGNED FOR THE CLIENT AND THE PROPERTY INDICATED ON THESE DRAWINGS ONLY AND SHALL NOT BE CONSTRUCTED FOR ANY OTHER CLIENT OR ANY OTHER PROPERTY. DO NOT SCALE DRAWINGS.</p>	<p>GOOD SHEPHERD CATHOLIC SCHOOL PLAYGROUND ASPHALT REPLACEMENT 4 EDITH ST. THAMESVILLE, ONTARIO NOP 2K0</p>	<p>DEMOLITION CONSTRUCTION NOTES</p>			 ROA STUDIO 67 KING STREET WEST, CHATHAM ON N7M 1C7 TEL . 519.397.0943 EMAIL . email@roastudio.com	<p style="writing-mode: vertical-rl; transform: rotate(180deg);">NOT FOR CONSTRUCTION</p>	<table border="1"> <tr><td>2</td><td>ISSUED FOR BIDS</td><td>05.24.2019</td></tr> <tr><td>1</td><td>ISSUED FOR OWNER'S 99% REVIEW</td><td>05.16.2019</td></tr> <tr><td>NO.</td><td>DESCRIPTION</td><td>DATE</td></tr> </table>	2	ISSUED FOR BIDS	05.24.2019	1	ISSUED FOR OWNER'S 99% REVIEW	05.16.2019	NO.	DESCRIPTION	DATE	<p>ARCHITECTURE</p> <p>PROJECT ID: ROA19-010 DRAWN BY: J. CASSIDY REVIEWED BY: J. QUELLETTE DATE: 05.23.2019 SCALE: AS NOTED</p>	<p>AD101</p>
2	ISSUED FOR BIDS	05.24.2019																
1	ISSUED FOR OWNER'S 99% REVIEW	05.16.2019																
NO.	DESCRIPTION	DATE																

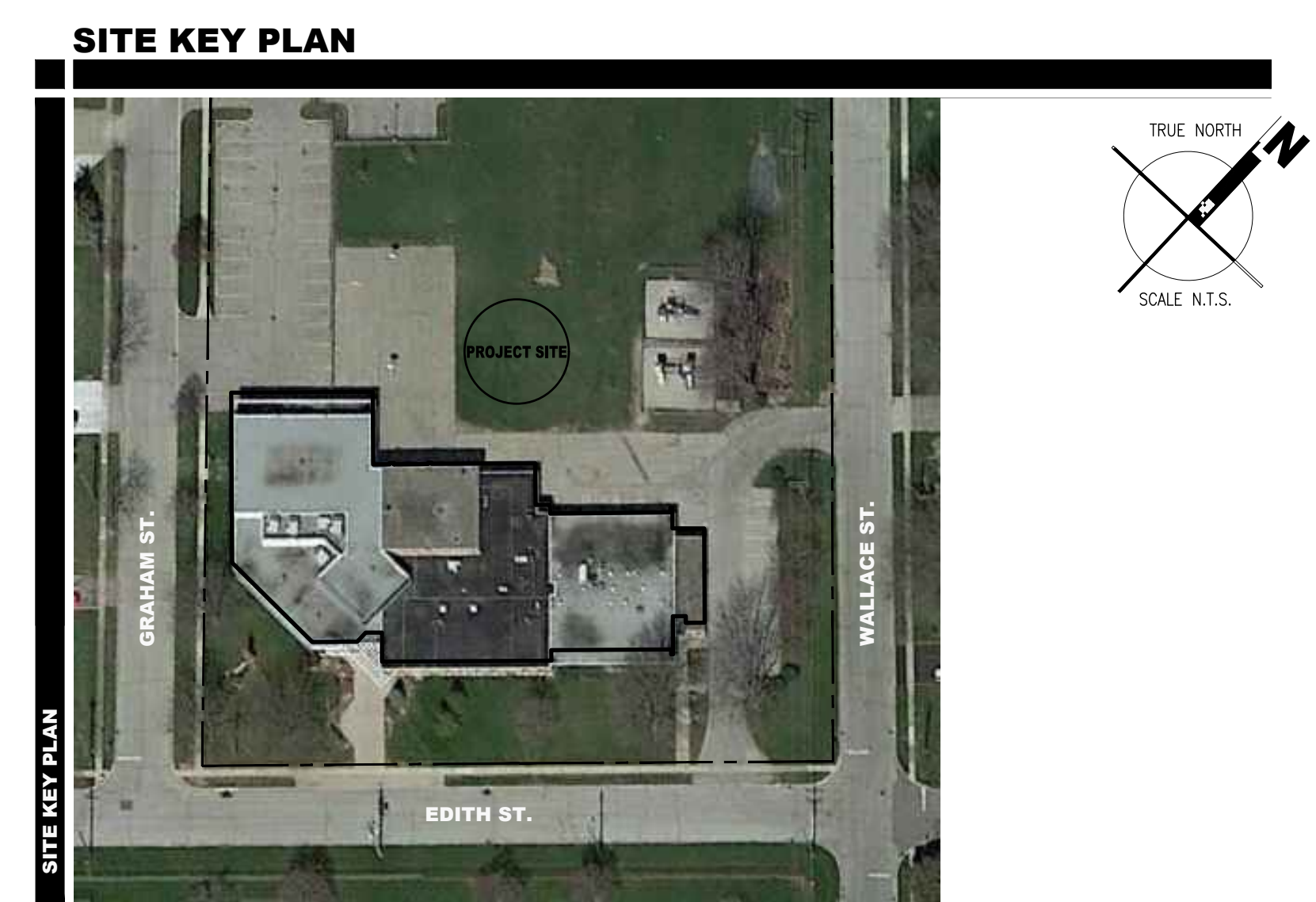
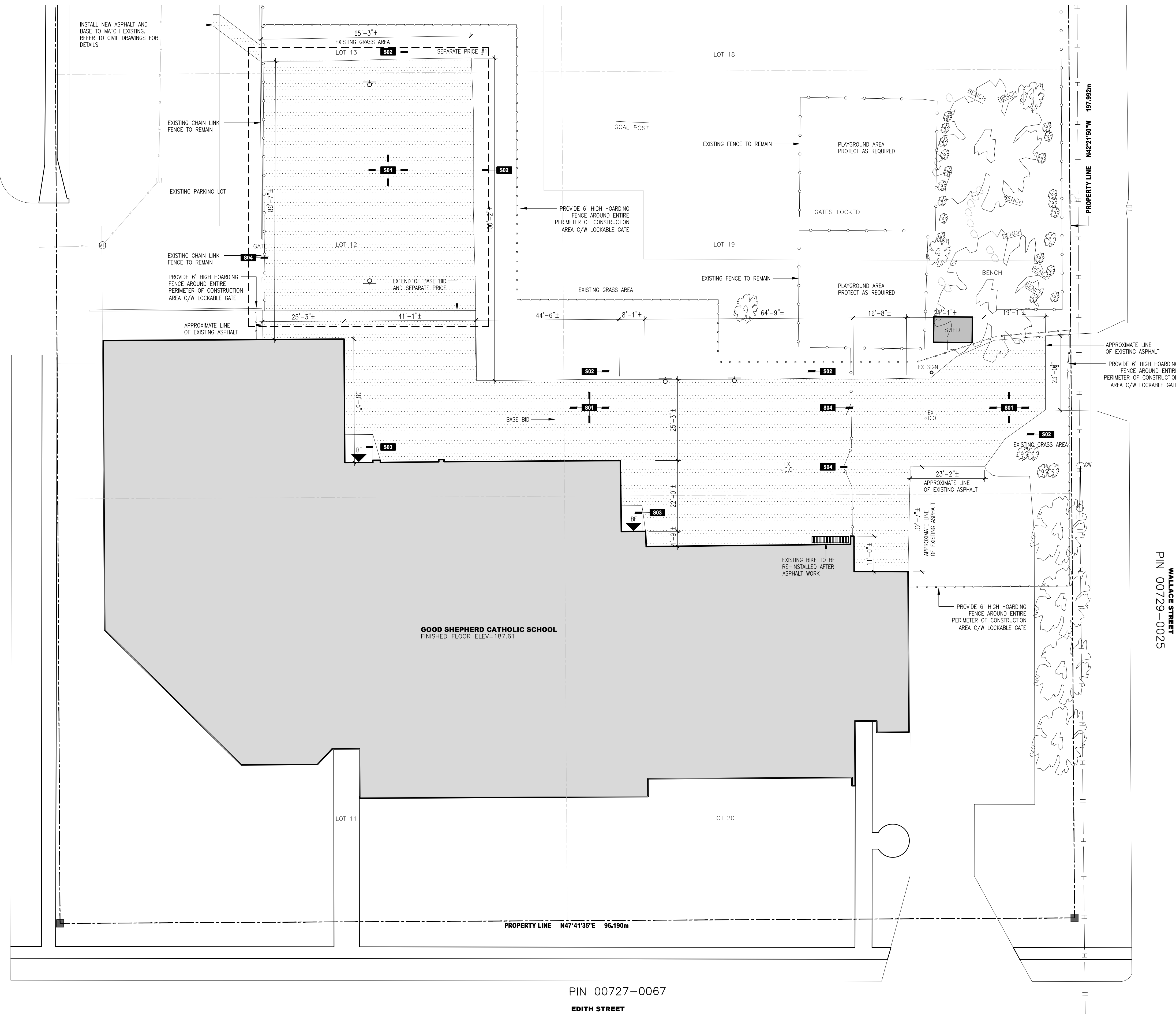

- SITE DEMOLITION NOTES**
- S01** SAW-CUT AND REMOVE EXISTING ASPHALT, RE-GRADE AND COMPACT EXISTING BASE. REFER TO CIVIL FOR ADDITIONAL CONSTRUCTION NOTES.
 - S02** REMOVE EXISTING CONCRETE SLAB COMPLETE.
 - S03** REMOVE EXISTING BIKE RACK, STORE AND REINSTALL ONCE ASPHALT WORK IS COMPLETE.
- SITE CONSTRUCTION NOTES**
- S01** INSTALL NEW ASPHALT PAVING ON EXISTING COMPACTED GRANULAR BASE. REFER TO CIVIL DRAWINGS FOR ADDITIONAL DETAILS AND GRADES.
 - S02** AFTER INSTALLATION OF NEW ASPHALT, RE-GRADE & HYDROSEED DAMAGED AREAS.
 - S03** RAMP ASPHALT TO WITH IN 1/2" OF UNDER SIDE OF EXISTING DOOR. REFER TO CIVIL.
 - S04** INSTALL EMERGED GALVANIZED METAL SLEEVE INSERT FOR GATE LOCKING PINS.

- GENERAL SITE NOTES**
- THIS DRAWING SHALL BE READ IN CONJUNCTION WITH THE CIVIL DRAWINGS AND THE SPECIFICATIONS. ALL WORK TO BE COORDINATED AND VERIFIED PRIOR TO CONSTRUCTION.
 - THE CONTRACTOR IS RESPONSIBLE FOR VISITING THE SITE TO VERIFY ALL SITE DIMENSIONS, SPOT ELEVATIONS AND REPORT AND DISCREPANCIES TO THE CONSULTANTS PRIOR TO CONSTRUCTION.
 - REPLACE, REPAIR AND MAKE GOOD ALL EXISTING CONCRETE SIDEWALKS, GRASSED AND MULCHED AREAS THAT ARE DAMAGED AS A RESULT OF THIS WORK. THIS INCLUDES ANY AREAS DAMAGED OUTSIDE THE LIMITS OF THE CONTRACT. CONTRACTOR TO DOCUMENT EXISTING SITE CONDITIONS WITH PHOTOGRAPHS PRIOR TO CONSTRUCTION.
 - CONTRACTOR IS RESPONSIBLE FOR MAINTAINING ACCESS AND EGRESS TO ALL EXISTING BUILDING, WALKWAYS, LANES ROADS AND PARKING LOTS IN THE SURROUNDING AREA.
 - CONTRACTOR IS RESPONSIBLE FOR REMOVAL OF ALL DEMOLISHED MATERIALS AND DEBRIS FROM THE SITE. ALL SALVAGED MATERIAL TO BE PROTECTED AND STORED UNTIL REUSE OR TURNED OVER TO OWNER.

SITE SYMBOL LEGEND

SYMBOL	DESCRIPTION	SYMBOL	DESCRIPTION	SYMBOL	DESCRIPTION
— 00	CONSTRUCTION NOTE	□	NEW CONCRETE	▒	EXISTING BUILDING
— 01	DEMOLITION NOTE	⚡	FIRE DEPT CONNECTION	▼	ENTRANCE EXIT
□	EX CATCH BASIN	○	EXISTING TREE	BF	BARRIER FREE ENTRANCE EXIT
— GW	GUIDE WIRE	○	EXISTING HYDRO POLE	— — —	HYDRO LINE REFER TO CIVIL DRAWINGS
↑	NORTH ARROW	— — —	PROPERTY LINE	EX C.O.	EXISTING CLEAN OUT
■	PROPERTY IRON BAR	□ CB	CATCH BASIN REFER TO CIVIL DRAWINGS	⊕	MANHOLE REFER TO CIVIL DRAWINGS
		○	VEGETATION		

01 CONSTRUCTION SITE PLAN

NOTES	PROJECT IDENTIFICATION	DRAWING IDENTIFICATION	ORIENTATION	SUB-CONSULTANT	PRIME CONSULTANT	DISCIPLINE SEAL	DRAWING SUBMISSION(S)	INTERNAL INFO	COPYRIGHT 2019												
<p>THE CONTRACTOR SHALL CHECK AND VERIFY ALL DIMENSIONS AND REPORT ANY ERRORS OR OMISSIONS TO THE ARCHITECT PRIOR TO COMMENCING OR PROCEEDING WITH ANY WORK ON THIS PROJECT. ALL DRAWINGS AND SPECIFICATIONS ARE THE PROPERTY OF THE ARCHITECT COPYRIGHT 2019. THESE DRAWINGS AND SPECIFICATIONS ARE DESIGNED FOR THE CLIENT AND THE PROPERTY INDICATED ON THESE DRAWINGS ONLY AND SHALL NOT BE CONSTRUCTED FOR ANY OTHER CLIENT OR ANY OTHER PROPERTY. DO NOT SCALE DRAWINGS.</p>	<p>GOOD SHEPHERD CATHOLIC SCHOOL PLAYGROUND ASPHALT REPLACEMENT 4 EDITH ST. THAMESVILLE, ONTARIO N0P 2K0</p>	<p>SITE PLAN CONSTRUCTION NOTES</p>			 67 KING STREET WEST, CHATHAM ON N7M 1C7 TEL . 519.397.0943 EMAIL . email@roastudio.com	<p>NOT FOR CONSTRUCTION</p>	<table border="1"> <thead> <tr> <th>NO.</th> <th>DESCRIPTION</th> <th>DATE</th> </tr> </thead> <tbody> <tr> <td>2</td> <td>ISSUED FOR BIDS</td> <td>05.24.2019</td> </tr> <tr> <td>1</td> <td>ISSUED FOR OWNER'S 99% REVIEW</td> <td>05.16.2019</td> </tr> <tr> <td>NO.</td> <td>DESCRIPTION</td> <td>DATE</td> </tr> </tbody> </table>	NO.	DESCRIPTION	DATE	2	ISSUED FOR BIDS	05.24.2019	1	ISSUED FOR OWNER'S 99% REVIEW	05.16.2019	NO.	DESCRIPTION	DATE	<p>ARCHITECTURE</p> <p>PROJECT ID: ROA19-010 DRAWN BY: J. CASSIDY REVIEWED BY: J. OUELLETTE DATE: 05.23.2019 SCALE: AS NOTED</p>	<p>A101</p>
NO.	DESCRIPTION	DATE																			
2	ISSUED FOR BIDS	05.24.2019																			
1	ISSUED FOR OWNER'S 99% REVIEW	05.16.2019																			
NO.	DESCRIPTION	DATE																			